

Piaggio would like to thank you

for choosing one of its products. We have drawn up this booklet to show you all features of our product. Please read the booklet carefully before using your vehicle. It includes information, suggestions and warnings regarding your vehicle. You will also be informed of features, details and devices that will prove the excellence of your choice. We believe that if you follow our suggestions you will soon tune in with your vehicle and use it for a long time at full satisfaction.

This booklet is an integral part of the vehicle, and upon sale, it should be transferred to the new owner.

Ape TM - Ape TM Diesel



INSTRUCTIONS

The instructions given in this booklet are intended to provide a clear, simple guide to using your scooter; details are also given of routine maintenance procedures and regular checks that should be carried out on the vehicle at an **Authorised PIAGGIO Dealer or Service Centre**. The booklet also contains instructions for simple repairs. Any operations not specifically described in this booklet require the use of special tools and/or particular technical knowledge: to carry out these operations refer to any **authorised PIAGGIO Dealer or Service Centre**. Read this booklet carefully before using your vehicle. Follow the instructions contained in this booklet for your personal safety and to ensure long-lasting use of your vehicle. Failure to observe these instructions may cause personal injury or damage to the vehicle.



Personal safety

Failure to completely observe these instructions will result in serious risk of personal injury.



Safeguarding the environment

Sections marked with this symbol indicate the correct use of the vehicle to prevent damaging the environment.



Vehicle intactness

The incomplete or non-observance of these regulations leads to the risk of serious damage to the vehicle and sometimes even the invalidity of the guarantee.

The signs indicated on this page are very important, they highlight the parts of the booklet that should be read with particular care. Each sign consists of a different graphic symbol, making it quick and easy to locate the various topics.

INDEX

- IDENTIFICATION.....** 7
 - Vehicle identification number..... 8
- SAFE RIDING.....** 11
 - Safe drive..... 12
 - Running-in period..... 12
- VEHICLE USE.....** 13
 - Checks..... 14
 - Before starting the engine..... 18
 - Engine start up..... 19
 - Stopping the engine..... 21
 - Starting difficulties..... 21
 - Gear position..... 22
 - Driving Tips..... 23
- DOORS AND LOCKS.....** 27
 - Keys..... 28
 - Door locking/unlocking by key..... 28
 - Front door windows..... 29
 - Engine inspection port..... 30
- SEATS AND SAFETY BELTS.....** 31
 - Using the safety belts..... 32
 - Fasting the safety belt..... 33
 - Adjusting the safety belt..... 34
 - To release the safety belt..... 34
- INSTRUMENT PANEL AND CONTROLS.....** 35
 - Handlebars..... 36
 - Steering wheel..... 39
 - Controls..... 43
 - Ignition switch..... 53
- GAUGES AND WARNING LIGHTS.....** 55
 - Instrument unit and indicators..... 56
- AIR CONTROL SYSTEM.....** 57
 - Heating..... 58
 - Heating and demisting..... 59

- Demisting..... 59
- MIRRORS AND WINDOW GLASSES.....** 61
 - Adjusting the mirror..... 62
 - Wipers and Brushes..... 62
- INSIDE EQUIPMENT.....** 65
- ELECTRICAL SYSTEM.....** 67
 - Fuel version..... 68
 - Diesel version..... 68
- EMERGENCY.....** 71
 - Wheel replacement..... 72
 - Maintenance instructions..... 72
- MAINTENANCE.....** 75
 - Check engine oil level..... 76
 - Oil change and oil filter replacement..... 76
 - Checking the brake fluid level..... 79
 - Gear box oil level..... 81
 - Window washer fluid level..... 83
 - Cooled fluid..... 83
 - Changing the engine cooling fluid..... 84
 - Checking and replacing the air cleaner element..... 84
 - Replacing the fuel filter..... 85
 - Air bleeding..... 86
 - Fuel exhaustion..... 86
 - Checking and replacing the pre-heating plugs..... 87
 - Fuses..... 88
 - Exhaust circulation system (EGR)..... 91
 - Tyres..... 91
 - Pressure..... 92
 - Periods of inactivity..... 92
 - Troubleshooting / What to do if..... 98
- SPARE PARTS AND ACCESSORIES.....** 107
 - Warnings..... 108
- TIPPER VERSION.....** 109

System Operation.....	110
Warnings for Loading and Unloading Operations.....	111
Scheduled Maintenance.....	114
Extraordinary Maintenance.....	116
Trouble-Shooting.....	117
Warning Plate Symbols.....	120
technical sheet for EC conformity declaration.....	123
Preface.....	123
Equipment Layout.....	124
Analysis of Risks Connected with the Layout and Operation of the Equipment.....	127
TECHNICAL DATA.....	135
Vehicle.....	138
SCHEDULED MAINTENANCE - CHECKS.....	149
Scheduled maintenance service.....	150

Ape TM - Ape TM Diesel



VEICOLI TRASPORTO LEGGERO



Chap. 01
Identification

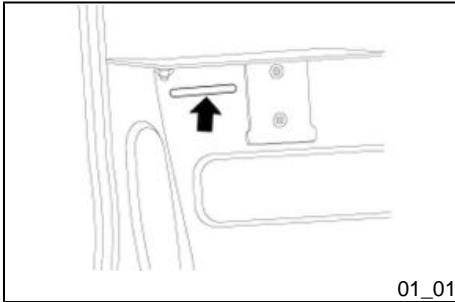

Vehicle identification number (01_01, 01_02, 01_03)

The identification codes consist of a prefix followed by a number punched on the chassis and on the engine, respectively.

Always quote the serial numbers when ordering spare parts.

The chassis identification number is located on the crossmember under the seat as shown in the figure.

The frame identification code is:

ZAPT100000001001

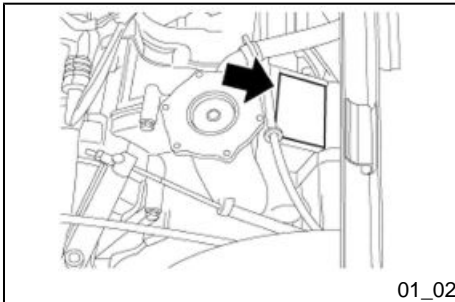

Check that the chassis prefix and number punched on the vehicle correspond to that shown on the vehicle documents.

The engine identification number is printed as shown in the figure.

The first indicates the location of the plate on the diesel engine, while the second is on the gasoline engine.

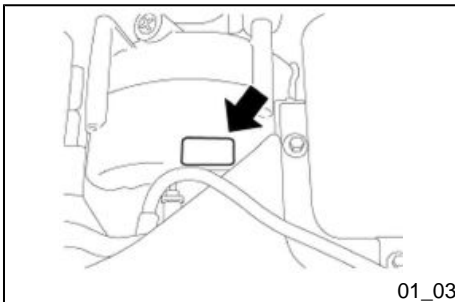

The gasoline version engine identification initials are:

ATM2M

The diesel version engine identification initials are:

LDW 422

CAUTION



**BE REMINDED THAT ALTERING IDENTIFICATION REGISTRATION NUMBERS
MAY LEAD TO SERIOUS PENAL SANCTIONS (IMPOUNDING OF THE VEHICLE.
ETC.)**

Ape TM - Ape TM Diesel



VEICOLI TRASPORTO LEGGERO



Chap. 02
Safe riding

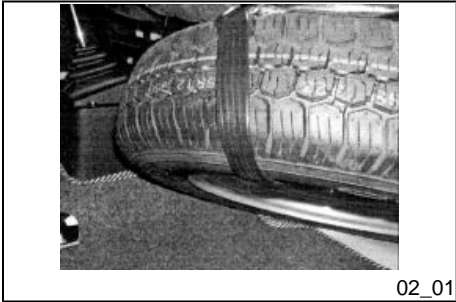

Safe drive (02_01)

ENSURE THE SPARE WHEEL IS CORRECTLY SECURED TO THE SEAT THROUGH THE RETAINING STRAP, IN ORDER TO PREVENT IT FROM MOVING IN THE EVENT OF AN EMERGENCY STOP.

Running-in period

During the first 1000 km, do not twist the throttle fully open and avoid driving at constant speed over long stretches of roads. After the first 1000 km gradually increase speed until reaching the maximum performance.

Ape TM - Ape TM Diesel



VEICOLI TRASPORTO LEGGERO



Chap. 03
Vehicle use

Checks (03_01, 03_02, 03_03, 03_04)

Before using the vehicle, check:

1. That the oil and fuel (for fuel versions) tanks are filled.
2. The engine/transmission oil level (for diesel versions).
3. The brake fluid level.
4. That the tyre inflation pressure is correct.
5. Correct operation of side/taillights, headlights and turn indicators.
6. Front and rear brake operation.
7. Gearbox oil level (for petrol versions).
8. Electrolyte and battery charge check.
9. Check coolant (diesel version)

CAUTION



TYRE PRESSURE SHOULD BE CHECKED WHEN TYRES ARE COLD.

TYRE PRESSURE

Front tyre pressure	2.5 atm
Rear tyre pressure	4.5 atm

Fuel tank

The fuel filler cap is fitted with a lock.

To open: insert the supplied key and turn it anticlockwise.

To close: put the filler cap back in position, turn the key clockwise and remove.

For petrol versions, the recommended fuel is as follows:

- unleaded petrol.

For diesel versions, the recommended fuel is as follows:

- diesel normally found on the market.

To this purpose please note that at low temperatures the paraffin elements contained in diesel spontaneously dissociate, thereby decreasing fluidity. If it is not possible to use winter type diesel, mix diesel with a special additive in the amounts indicated on the container.

The additive must be poured into the tank before the diesel and before the process described above since a late addition generates no effects.

CAUTION



- **WHEN REFUELLING, KEEP THE CAP CLEAN FROM DUST AND DIRT.**

CAUTION



BEFORE REFUELLING, STOP THE ENGINE. PETROL IS HIGHLY INFLAMMABLE. DO NOT DROP PETROL ON HOT ENGINE PARTS. DO NOT SMOKE. KEEP NAKED FLAMES AWAY: FIRE HAZARD. DO NOT INHALE PETROL FUMES.

FUEL

Total capacity:	15 litres
Fuel	(Unleaded petrol)

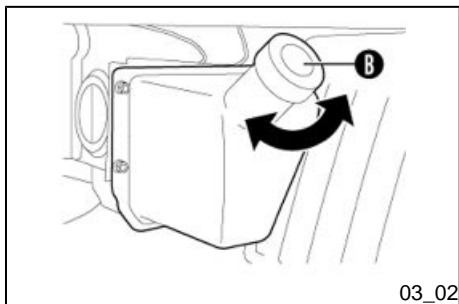
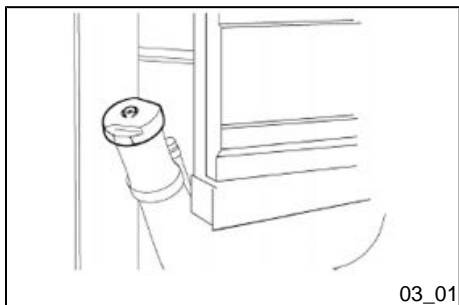

Oil tank (for petrol versions)

The oil tank is provided with a light reserve indicator on the instrument panel.

To top up, remove cap «B» and pour in new oil.

CAUTION



USING OTHER TYPES OF OIL CAN COMPROMISE ENGINE DURABILITY.

Recommended products

AGIP CITY TEC 2T

Oil for 2-stroke petrol engines

JASO FC, ISO-L-EGD Specifications

Characteristic

Mixer oil (2.0 l)

RESERVE: 0.6 l

Removing the battery

The battery is located under the seat. The latter can be easily tilted removing the two nuts «A» located at the two ends below the seat, as shown in the figure.

If it is necessary to remove the battery from its housing (for replacing or charging it), disconnect the cables, remove nut «B» and release the battery from the locking bracket «C».

CAUTION



NEVER DISCONNECT THE BATTERY WHEN THE ENGINE IS RUNNING TO AVOID DAMAGING THE ELECTRICAL SYSTEM.



BATTERY ELECTROLYTE CONTAINS SULPHURIC ACID: AVOID CONTACT WITH EYES, SKIN AND CLOTHES. IN THE EVENT OF ACCIDENTAL CONTACT, RINSE WITH PLENTY OF WATER AND SEEK MEDICAL ADVICE

WARNING



USED BATTERIES ARE HARMFUL FOR THE ENVIRONMENT AND MUST BE COLLECTED AND DISPOSED OF IN COMPLIANCE WITH THE LAW.

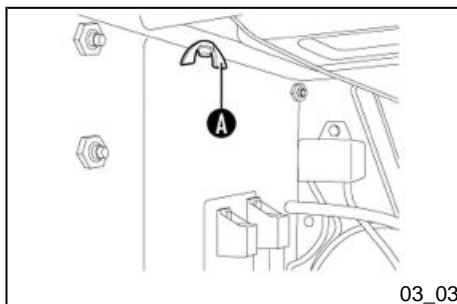

03_03

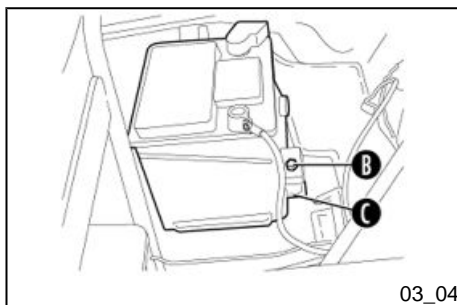

03_04

Installing a new battery

Make sure the terminals are fitted correctly. The battery is an electrical device that requires careful checks and diligent maintenance.

CAUTION



DO NOT INVERT THE POLARITIES: DANGER OF SHORT-CIRCUIT AND FAULTS IN THE ELECTRICAL DEVICES.

Checking electrolyte level

The electrolyte level must be checked frequently and must reach the maximum level. Top up exclusively with distilled water.

If the battery requires topping up too frequently, check the electrical system - the battery is probably working in overload conditions, which will lead to rapid deterioration.

Before starting the engine

- Ensure that the parking brake is released.
- Ensure that the reverse gear control lever is forward or backward according to whether you want to move forward or in reverse.
- Ensure that the gear control lever is in neutral position: position **N** for the handlebar version, central lever position for the steering wheel version.

THIS PRELIMINARY OPERATION IS NOT REQUIRED IN THE STEERING WHEEL DIESEL VERSION.

Engine start up (03_05, 03_06)

Engine ignition (gasoline version)

Open the fuel cock «A» (turn it counter clockwise to open and clockwise to close).

With cold engine, pull the starter lever «C» and insert the start key into the key switch, then turn it to position 2 and at the same time press the accelerator control.

After start up, release the key that will automatically return to position 1.

WARNING



EXHAUST GASES ARE TOXIC. DO NOT START THE ENGINE IN A CLOSED PLACE.



WHEN THE ENGINE IS ON, DO NOT HANDLE PARTS AND CONNECTIONS OF THE ELECTRIC SYSTEM, ESPECIALLY THE SPARK PLUG CABLE.

Engine start up (03_06, 03_07)

Engine ignition (diesel version)

Introduce the start key into the switch and move it to position 1. On the instrument panel, the glow plug preheat indicator will light up. The hotter the engine, the sooner the indicator will turn off. Then move the key to position 2 while pressing the accelerator control at the same time. After start up, release the key that will automatically return to position 1.

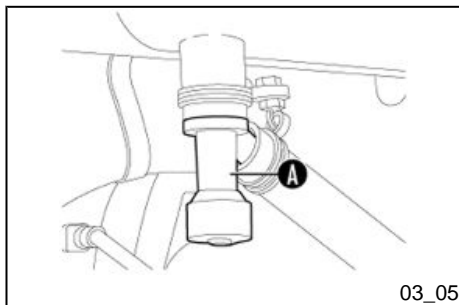

03_05

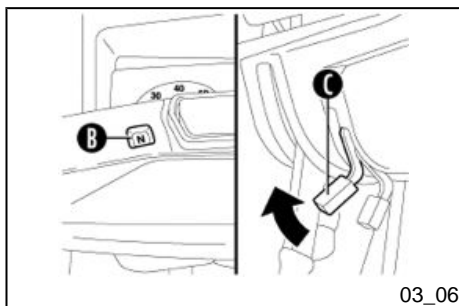

03_06

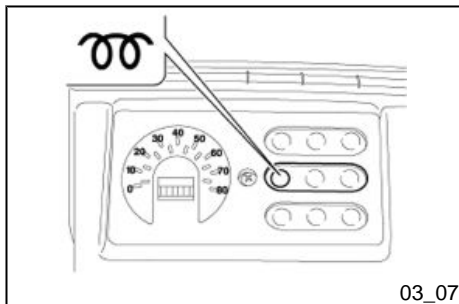

03_07

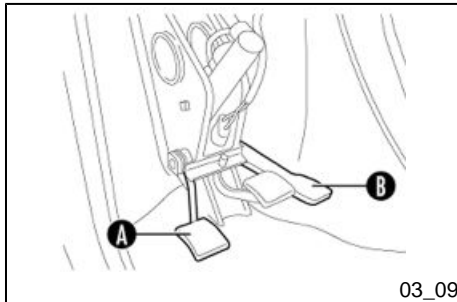
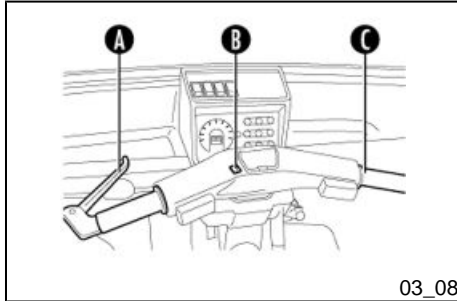
**WARNING**

EXHAUST GASES ARE TOXIC. DO NOT START THE ENGINE IN A CLOSED PLACE.

Engine start up (03_07, 03_08)**Starting off (versions with handlebar)**

With idle engine, pull the clutch lever «**A**» and turn the gear knob to the 1st gear (position **1** on the gear indicator «**B**»). To start off, release the clutch lever «**A**» smoothly and accelerate by turning the throttle twist grip «**C**».

WARNING

EXHAUST GASES ARE TOXIC. DO NOT START THE ENGINE IN A CLOSED PLACE.

Engine start up (03_08, 03_09)**Start-up (handlebar versions)**

With idle engine, press the clutch pedal «**A**» and engage the first gear with the gearbox lever. Gently release the clutch pedal while gradually pressing the accelerator pedal «**B**».

Stopping the engine

Stopping the engine (handlebar)

Before stopping the engine, shift to neutral (position «N» on the gear indicator « **B** »). Then turn the ignition key to «**A**».

Stopping the engine (steering wheel)

Before stopping the engine, move the gearbox to neutral (central position), then turn the switch key to position «**A**».

Starting difficulties

Engine starting difficulties (gasoline version)

Possible causes and suggested actions:

- Carburettor flooded.

Close the fuel cock, turn the start key to position "1"; with closed starter open the gas thoroughly and actuate the key switch, moving it to position "2"; open the fuel cock again and move the key switch to position "2". In any case, do not try starting for more than 5-6 times.

- Dynamotor or battery inefficiency.

Use an auxiliary battery with equivalent or slightly higher specifications with respect to the original battery.

If you need to bump start the vehicle (by pushing or towing), follow these instructions: engage a high gear (2nd or 3rd), do not exceed 20 kph (even when freewheeling), release the clutch pedal or lever gradually.

Before performing this operation, check the reverse lever position. If you cannot start the engine even with the procedure described above, contact an **Authorised PIAGGIO Service Centre**.

CAUTION



NEVER STRESS THE ENGINE AT LOW TEMPERATURES IN ORDER TO AVOID POSSIBLE DAMAGE. WHEN DRIVING DOWNHILL, DO NOT EXCEED TOP SPEED OR THE ENGINE COULD BE DAMAGED BY PROLONGED OVERREVING.

CAUTION



- **AFTER A LONG JOURNEY ALLOW THE ENGINE TO RUN AT IDLE SPEED FOR A FEW SECONDS BEFORE SWITCHING IT OFF.**

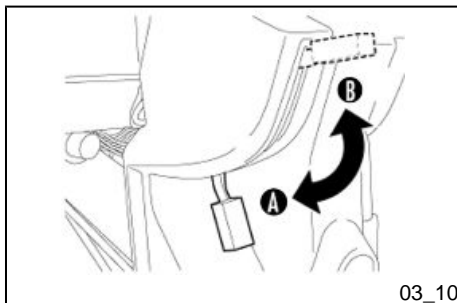

Gear position (03_10, 03_11, 03_12)

To reverse the vehicle, proceed as follows:

1. Stop the vehicle completely and turn the gear selector to neutral (position «N» on the gear indicator «B») while the engine is idling;
2. For gasoline versions, lift the reverse gear control lever from position «A» to position «B».
3. Diesel versions are not equipped with a reverse gear control lever.
4. Use the gear control lever to engage gears; («1stgear» for the gasoline version, «R» for the handlebar version), and gently release the clutch pedal while gradually pressing the accelerator pedal.

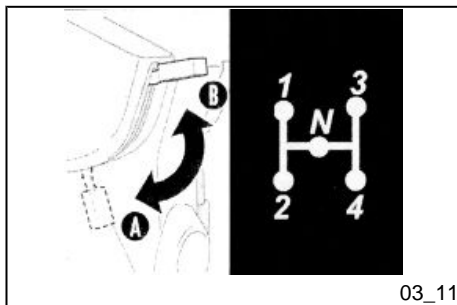

5. To shift from reverse gear to the forward gears repeat the previously described procedures and move the reverse gear control lever to the «A» position (in the gasoline version and in the handlebar version).

Note: in the diesel handlebar version, once the reverse gear control lever has been moved to the «B» position, both the reverse gear and the «1st gear» can be used for vehicle parking manoeuvring; engagement of higher gears remains disabled until the reverse gear control lever is set to the «A» position.

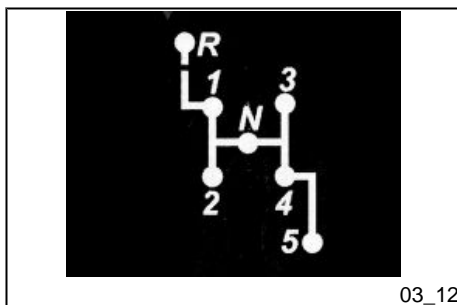

Driving Tips

Follow these simple recommendations to use your vehicle every day, confidently and safely.

Your ability and your mechanical knowledge form the basis of safe riding. Practice driving in a traffic-free area until you acquire a good knowledge of the vehicle.

1. Always drive within the limits of your ability, strictly following the road regulations of the country where you are driving.

2. Carefully adjust the position of rear-view mirrors, to easily check the road behind you.
3. Ensure nothing hinders the pedals stroke (mats, etc.)
4. Ensure that headlights are working properly.
5. To start the vehicle, with idle engine, engage the first gear and gently release the clutch lever, accelerating at the same time.
6. Reduce speed on badly surfaced roads and drive with caution.
7. Do not brake fully on wet, unsurfaced or slippery roads.
8. Do not shift down when the engine is running at high revs to avoid dangerous over-revving.
9. On a downhill, do not keep the gearbox to neutral position or the engine off, but decrease speed closing the accelerator. To facilitate the decrease of speed, use the brakes without pulling them for too long, to prevent dangerous overheating that would decrease their efficiency. Shift down to increase the engine brake effect.
10. For rapid pick-up, e.g. for overtaking, shift down a gear to employ all the required power.
11. When driving up demanding slopes, shift down to employ all the required power.
12. Check that the load is evenly distributed on the loading body, and do not exceed the provided loads (see chapter: "Technical data -performance") to prevent tilting while turning on a corner.



ALWAYS DRIVE YOUR VEHICLE WITHIN THE LIMITS OF YOUR ABILITY. DRIVING WHILE DRUNK OR UNDER THE EFFECT OF DRUGS OR CERTAIN MEDICINES IS EXTREMELY DANGEROUS AND INFRINGES THE ROAD REGULATIONS.



ANY CHANGES TO VEHICLE PERFORMANCE, AS WELL AS ALTERATIONS TO ORIGINAL STRUCTURE PARTS, RENDERS THE VEHICLE NO LONGER CONFORMING TO THE APPROVED TYPE AND THEREFORE DANGEROUS FOR DRIVING SAFELY.

Ape TM - Ape TM Diesel



VEICOLI TRASPORTO LEGGERO



Chap. 04
Doors and locks



Keys (04_01)

The vehicle is supplied with two copies of the key.

«A»: key for the ignition and start-up switch, the door lock and the fuel tank cover.

The code numbers, in fact, are the only way to identify the key for future copies.

YOU SHOULD KEEP A DUPLICATED KEY AND ITS CORRESPONDING CODE IN ANY PLACE OTHER THAN THE VEHICLE.

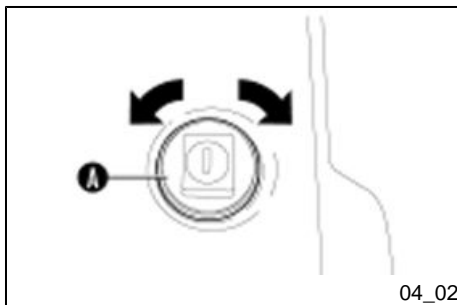

Door locking/unlocking by key (04_02, 04_03)

The doors are provided with antitheft device. To open turn the key clockwise and press button «A». To close turn the key anticlockwise.

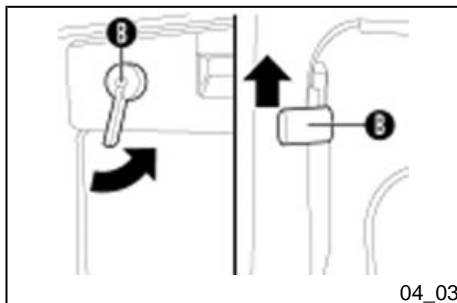

04_03

To open both doors from the inside, use the special release control «B».

For the handlebar version, the release control «B» must be lifted, while for the steering wheel version it must be pushed rightwards.

MAKE SURE IT IS SAFE TO OPEN THE DOORS BEFORE OPENING THEM. BEFORE STARTING OFF, MAKE SURE THE DOORS ARE CLOSED AND LOCKED. THIS PRECAUTION WILL ENSURE THEY DO NOT OPEN ACCIDENTALLY WHICH WOULD BE A HAZARD FOR THE DRIVER



04_04

Front door windows (04_04)

To open the windows, press the release lever while moving the handle downwards. (7 fixed positions are available).

To close the windows, move the handle to "travel end top" position.

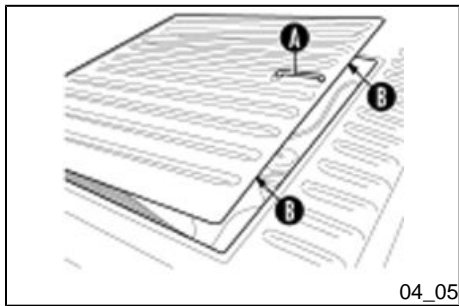

Engine inspection port (04_05)

Lower the rear side board and grip the handle «A» pulling it upwards to release the retain clips «B».

On the vehicles with loading body in light alloy with tilting, to access the engine compartment it is necessary to lower the side and rear boards and then tilt the loading body.

Use the special safety bar to secure the loading body in tilted position.

NEVER WORK UNDERNEATH THE LOADING BODY WHEN IT IS TILTED WITHOUT HAVING FIRST SECURED THE SAFETY BAR. DANGER OF SERIOUS INJURY.

Ape TM - Ape TM Diesel



VEICOLI TRASPORTO LEGGERO



Chap. 05
Seats and safety
belts

Using the safety belts

Observe the following suggestions for using the seat belts correctly. Failure to follow these instructions may lead to severe injury in the event of an accident or sudden braking. Check the seat belts periodically to ensure proper functioning. If its operation appears faulty, have it checked at an **Authorised PIAGGIO Service Centre** immediately.

Pregnant women: PIAGGIO recommends using the seat belt. The waist height seat belt length should adhere snugly to your body as low as possible (on the hips) and not at your waist. Ask your doctor for advice.

Injured people: PIAGGIO recommends using the seat belt. Ask your doctor for advice.

WARNING



THE SAFETY BELTS ARE DESIGNED TO EXERT THEIR ACTION ON THE BONE STRUCTURE OF YOUR BODY. THE DIFFERENT BELT SECTIONS SHOULD FIT SNUGLY TO THE PELVIS, THE CHEST AND SHOULDERS. DO NOT WEAR THE SECTION WHICH IS SUPPOSED TO FIT ON THE HIPS OVER THE ABDOMEN. SAFETY BELTS SHOULD BE ADJUSTED TO FIT SNUGLY AND SHOULD BE ADAPTED TO THE PERSON WEARING THEM, SO AS TO OFFER THE PROTECTION THEY ARE DESIGNED FOR. A LOOSE BELT WOULD CONSIDERABLY REDUCE PROTECTION TO THE PASSENGER WEARING IT. BE CAREFUL NOT TO DAMAGE BELTS WHEN CLOSING THE DOORS. DO NOT REMOVE BELTS FOR CLEANING. WASH THEM WITH WATER AND NEUTRAL SOAP, RINSE AND LET DRY IN A WARM PLACE. PAY SPECIAL ATTENTION NOT TO DAMAGE THE SEAT BELTS WITH CLEANING PRODUCTS, OIL, ABRASIVE DETERGENTS, CHEMICAL AGENTS OR BATTERY FLUIDS

WARNING

AFTER A SEVERE ACCIDENT, IT IS ESSENTIAL TO HAVE THE ENTIRE SEAT BELT ASSEMBLY REPLACED, EVEN IF IT MAY NOT APPEAR DAMAGED. DO NOT WEAR A TWISTED SEAT BELT. DO NOT WEAR THE SEAT BELT WITH THE SHOULDER LENGTH UNDER YOUR ARM OR BEHIND YOUR BACK. DO NOT FASTEN THE SEAT BELT OVER HARD OR FRAGILE OBJECTS, SUCH AS GLASSES, JEWELLERY, PENS, KEYS. DO NOT WEAR THE SEAT BELT OVER VERY THICK CLOTHES, AS THIS MAY PREVENT IT FROM BEING POSITIONED CORRECTLY. DO NOT MODIFY OR DISASSEMBLE THE SEAT BELT ASSEMBLY. AFTER AN ACCIDENT OF A CERTAIN SEVERITY, WE RECOMMEND THAT YOU HAVE THE SEAT BELT WHICH WAS BEING WORN REPLACED AT AN AUTHORISED PIAGGIO SERVICE CENTRE, EVEN IF IT DOES NOT APPEAR DAMAGED.

Fastening the safety belt (05_01)

Take the metal tongue from its housing.

Insert the metal tongue in the buckle until it clicks.

CAUTION

TO GUARANTEE THE OPTIMAL PERFORMANCE OF THE SEAT BELT, AFTER HAVING INSERTED THE METAL TONGUE INTO THE BUCKLE, CHECK IT IS SECURELY BLOCKED AND THE SEAT BELT IS NOT TWISTED.

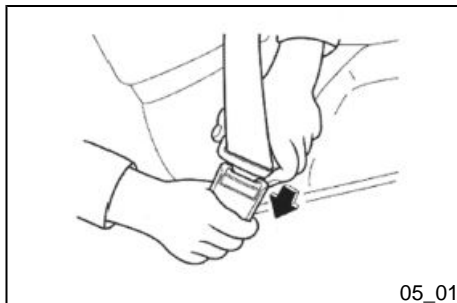

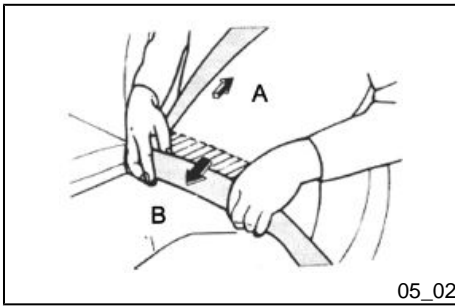

Adjusting the safety belt (05_02)

Position the seat belt as low as possible on your hips and not at your waist.

Adjust the seat belt so that you can slide your fist between the belt and your chest.

Hold the anchoring at a right angle with respect to the belt and pull the belt to lengthen or shorten it.

A: wrong

B: right

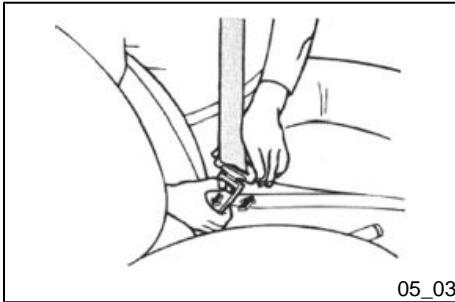

To release the safety belt (05_03)

Press the button. Insert the metal tongue in its housing when it is not in use.

CAUTION

TO PREVENT DAMAGING SEAT BELTS CHECK THEY DO NOT REMAIN PINCHED BETWEEN A DOOR AND THE CAR BODY, OR BEHIND THE SEAT BACK.

Ape TM - Ape TM Diesel



VEICOLI TRASPORTO LEGGERO



Chap. 06
Instrument panel
and controls

Handlebars (06_01)

Apetm

1. External light control switch
2. Tachometer and odometer
3. Ashtray
4. Gear indicator
5. Clutch lever
6. Cigar lighter
7. Turn indicator selector
8. Reverse gear command lever
9. Key switch
10. Emergency or parking brake
11. Heater control lever (red)
12. Starter lever (only in the gasoline version)
13. Brake pedal
14. Headlight switch
15. Horn button
16. Accelerator control
17. Light indicators unit
18. Emergency light switch
19. Rear fog light switch
20. Windscreen wiper control switch

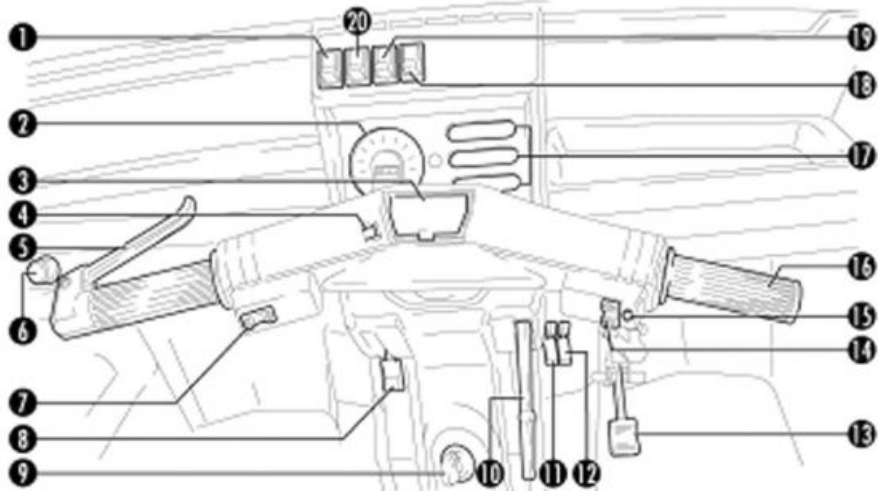

06_01

Handlebars (06_01, 06_02)

ApetmD

1. External light control switch
2. Tachometer and odometer
3. Ashtray
4. Gear indicator
5. Clutch lever
6. Cigar lighter

7. Turn indicator selector
8. Reverse gear command lever
9. Key switch
10. Emergency or parking brake
11. Heater control lever (red)
12. Airflow deflector lever: windscreen - floor heating
13. Brake pedal
14. Headlight switch
15. Horn button
16. Accelerator control
17. Light indicators unit
18. Heater fan switch
19. Rear fog light switch
20. Windscreen wiper control switch.
21. Emergency light switch
22. Body tilting button (where available).

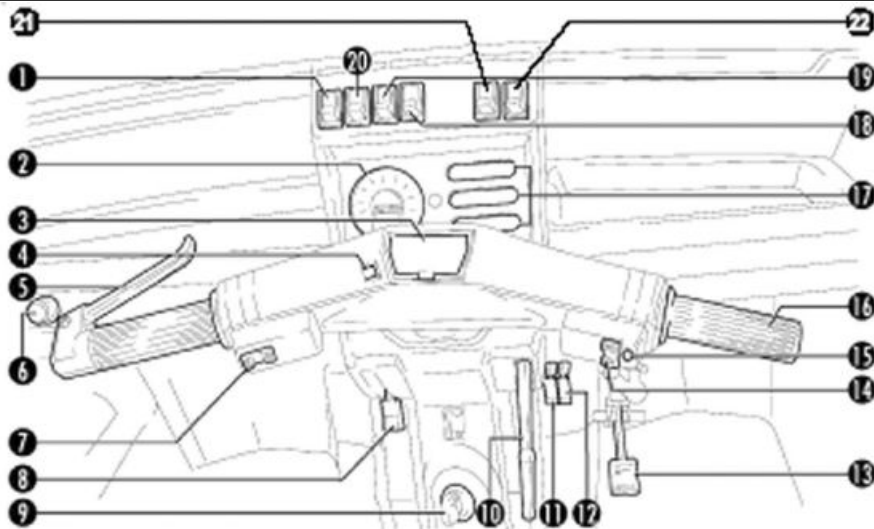

06_02

Steering wheel (06_03)

Apetm

1. Steering wheel
2. Flashing light switch lever
3. Light and horn switch lever
4. Key switch
5. Clutch pedal
6. Brake pedal

7. Accelerator pedal
8. External light control switch
9. Windscreen wiper control switch
10. Reverse gear control lever
11. Gearbox control lever
12. Emergency or parking brake
13. Heating control lever (red)
14. Starter lever (only gasoline version) (black)
15. Rear fog light switch
16. Cigar lighter
17. Emergency light switch
18. Ashtray
19. Light indicators unit
20. Tachometer and odometer

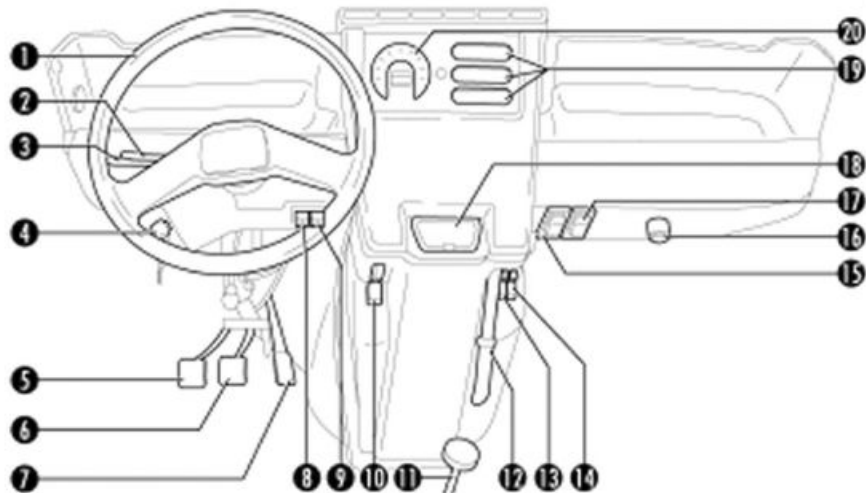

06_03

Steering wheel (06_03, 06_04)

ApetmD

1. Steering wheel
2. Flashing light switch lever
3. Light and horn switch lever
4. Key switch
5. Clutch pedal
6. Brake pedal

7. Accelerator pedal
8. External light control switch
9. Windscreen wiper control switch
10. Reverse gear control lever
11. Gearbox control lever
12. Emergency or parking brake
13. Heating control lever (red)
14. Airflow deflector lever: windscreen - floor heating
15. Rear fog light switch
16. Cigar lighter
17. Heater fan switch
18. Ashtray
19. Light indicators unit
20. Tachometer and odometer
21. Emergency light switch
22. Body tilting button (where available).

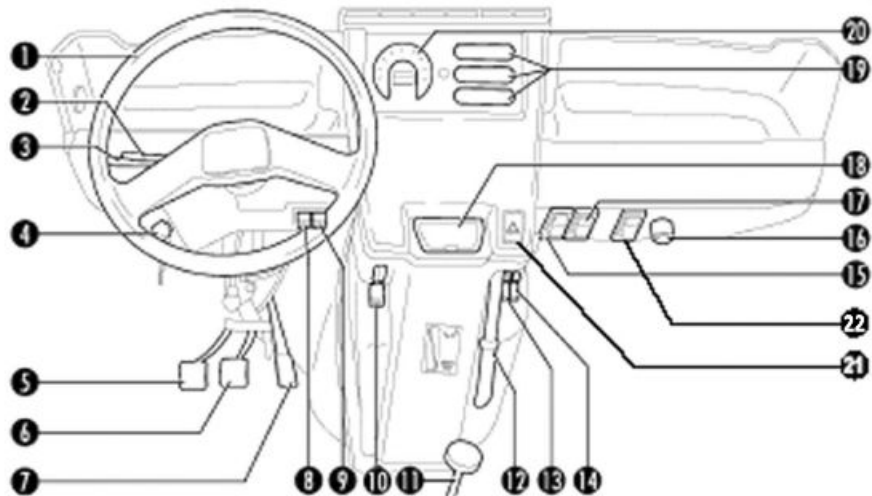

06_04

Controls (06_05, 06_06, 06_07, 06_08, 06_09)

HANDLEBAR VERSION - GASOLINE

External light control switch «A»

0 = Lights off;

1 = Front and rear side/taillights and instrument panel lights on;

2 = Headlights (high or dipped beams on).

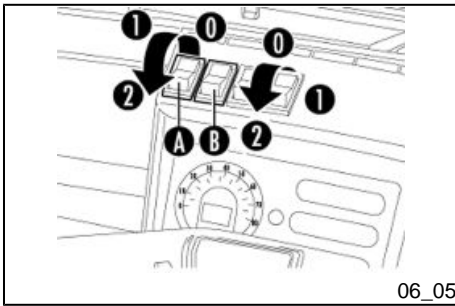

Windscreen wiper control switch «B»

0 = Disabled;

1 = Windscreen wiper enabled.

2 = Windscreen wiper + sprayer enabled.

Light selector «A»

1 = High beams on.

2 = Dipped beams;

THE SWITCH POSITIONS ARE SUBJECT TO THE OUTSIDE LIGHT CONTROL SWITCH POSITION.

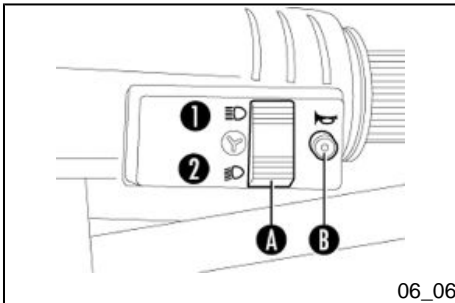

Horn button

B = horn button.

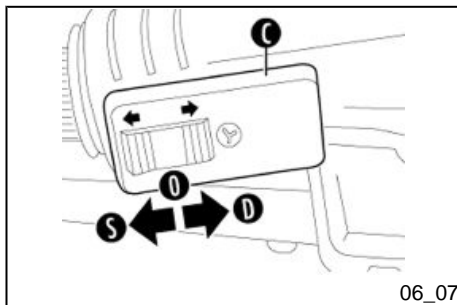

Turn indicator selector «C»

0 = Lights off;

S = Left turn indicators flashing;

D = Right turn indicators flashing.

Emergency light switch «B»

0 = Lights off;

1 = Direction indicators flashing

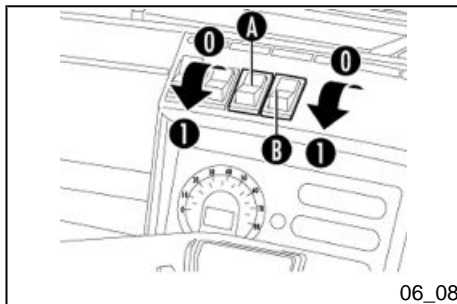

Rear fog light switch «A»

0 = Light off;

1 = Rear fog light on.

STEERING WHEEL VERSION - GASOLINE

Light and horn switch lever «A»

With external light control switch «B» in position enabled.

1 = Taillights on;

2 = Dipped beams on;

3 = High beams on.

To actuate the horn, press lever «A» upwards.

THE LIGHT SWITCH LEVER POSITIONS ARE SUBJECT TO THE OUTSIDE LIGHT CONTROL SWITCH POSITION.

Flashing light switch lever «C»

0 = Lights off;

S = Left turn indicators flashing;

D = Right turn indicators flashing.

External light control switch «A»

0 = Lights off;

1 = Lights on.

Windscreen wiper control switch «B»

0 = Disabled;

1 = Windscreen wiper enabled.

2 = Windscreen wiper + sprayer enabled.

Rear fog light switch «C»

0 = Light off;

1 = Rear fog light on.

Emergency light switch «D»

0 = Lights off;

1 = Direction indicators flashing

Cigar lighter«E»

Press the lighter button and wait until it automatically returns to its initial position. The lighter is ready for use.

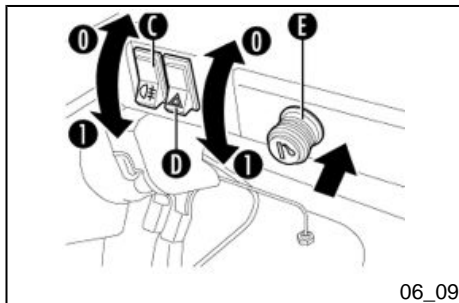

Controls (06_09, 06_10, 06_11, 06_12, 06_13, 06_14)

HANDLEBAR VERSION - DIESEL

External light control switch «A»

0 = Lights off;

1 = Front and rear side/taillights and instrument panel lights on;

2 = Headlights (high or dipped beams on).

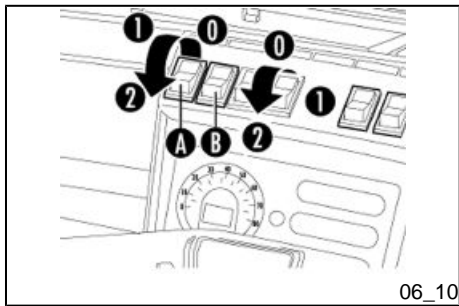

Windscreen wiper control switch «B»

0 = Disabled;

1 = Windscreen wiper enabled.

2 = Windscreen wiper + sprayer enabled.

Light selector «A»

1 = High beams on.

2 = Dipped beams;

THE SWITCH POSITIONS ARE SUBJECT TO THE OUTSIDE LIGHT CONTROL SWITCH POSITION.

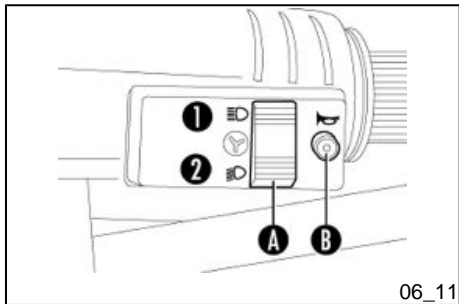

Horn button

B = horn button.

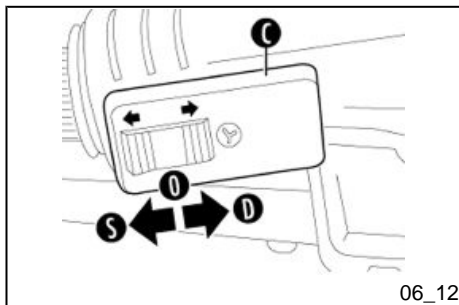

Turn indicator selector «C»

0 = Lights off;

S = Left turn indicators flashing;

D = Right turn indicators flashing.

Rear fog light switch «A»

0 = Light off;

1 = Rear fog light on.

Heater fan switch «B»

0 = Fan off

1 = First gear

2 = Second gear

Emergency light switch «A»

0 = Lights off;

1 = Direction indicators flashing

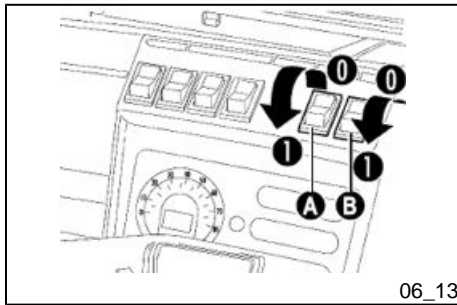

Body tilting button «B» (where available)

0 = Body down

1 = Body up

In order to improve safety and prevent unintentional operations, the lifting controls only becomes live after releasing the safety lever on the right hand side at the back of the cabin.

Remember to bring the safety lever back onto the 'blocked' position once all tilting operations are completed.

- **THE BODY LIFTING OPERATIONS MUST BE CARRIED OUT WITH THE VEHICLE STOPPED AND THE EMERGENCY/PARKING BRAKE ACTIVATED.**

STEERING WHEEL VERSION - DIESEL

Light and horn switch lever «A»

With external light control switch «B» in position enabled.

1 = Taillights on;

2 = Dipped beams on;

3 = High beams on.

To actuate the horn, press lever «A» upwards.

THE LIGHT SWITCH LEVER POSITIONS ARE SUBJECT TO THE OUTSIDE LIGHT CONTROL SWITCH POSITION.

Flashing light switch lever «C»

0 = Lights off;

S = Left turn indicators flashing;

D = Right turn indicators flashing.

External light control switch «A»

0 = Lights off;

1 = Lights on.

Windscreen wiper control switch «B»

0 = Disabled;

1 = Windscreen wiper enabled.

2 = Windscreen wiper + sprayer enabled.

Rear fog light switch «C»

0 = Light off;

1 = Rear fog light on.

Heater fan switch «D»

0 = Fan off

1 = First gear

2 = Second gear

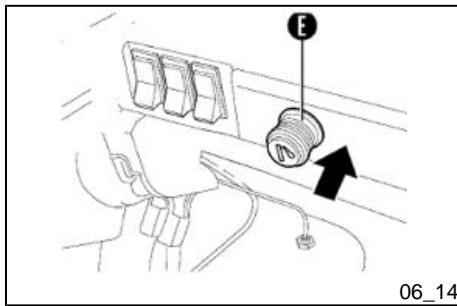

06_14

Cigar lighter «E»

Press the lighter button and wait until it automatically returns to its initial position. The lighter is ready for use.

Emergency light switch «F»

0 = Lights off;

1 = Emergency light on.

Body tilting button «G»

0 = Body down

1 = Body up

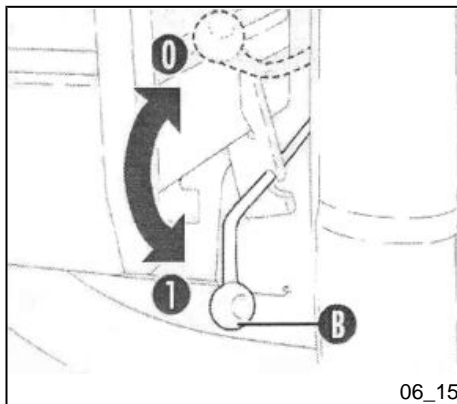

06_15

In order to improve safety and prevent unintentional operations, the lifting control only becomes live after releasing the safety lever on the right hand side at the back of the cabin.

Remember to bring the safety lever back onto the 'blocked' position once all tilting operations are completed.

- **TIPPING ACTIONS OF THE PLATFORM MUST BE CARRIED OUT WHEN THE VEHICLE IS STOPPED AND THE HANDBRAKE ENGAGED.**

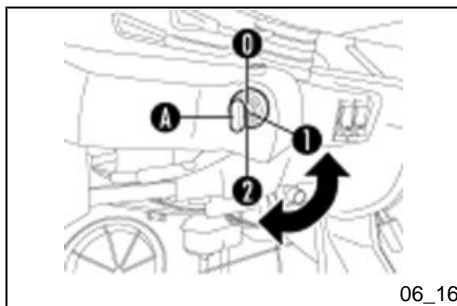

06_16

Ignition switch (06_16, 06_17)

According to the version (steering wheel or handlebar), the key switch is on the left of the steering wheel or on the front side, on the steering column cover.

The key can turn to 3 different positions:

0 = Ignition off, key can be removed, steering locked.

1 = Running position - arrangement of utilities and external lights and start up of pre-heating glow plug (for diesel versions).

2 = Engine start up (after start up, the key automatically returns to the running position "1").

Locking the steering (antitheft): with the key switch set to 0, extract the key and turn the steering wheel leftwards (travel end).

Unlocking the steering: insert the key and turn it to 1.

Steering wheel lock (antitheft): with the key switch set to 0, extract the key and turn the steering wheel to lock it.

Steering wheel release: insert the key and turn it to 1.

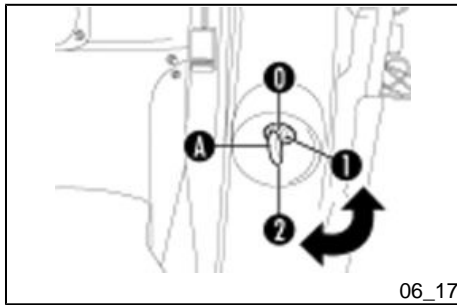

DO NOT TURN THE KEY TO POSITION 0 WHILE DRIVING.

WARNING



SHOULD THE STARTING DEVICE BE TAMPERED WITH (E.G. A THEFT ATTEMPT) HAVE IT CHECKED AT THE EARLIEST OPPORTUNITY BY A DEALER OR AN AUTHORISED PIAGGIO SERVICE CENTRE BEFORE YOU START DRIVING AGAIN.

WHEN YOU LEAVE THE VEHICLE, ALWAYS REMOVE THE KEY TO PREVENT SOMEBODY FROM ACCIDENTALLY ACTUATING THE CONTROLS. ENGAGE THE PARKING BRAKE AND THE FIRST OR REVERSE GEAR ACCORDING TO WHETHER THE VEHICLE IS UPHILL OR DOWNHILL. SUITABLY TURN THE STEERING WHEEL TO PREVENT BLOCKING THE ROAD IN CASE OF AN ACCIDENTAL RELEASE OF THE EMERGENCY OR PARKING BRAKES.

Ape TM - Ape TM Diesel



VEICOLI TRASPORTO LEGGERO



Chap. 07
Gauges and
Warning Lights

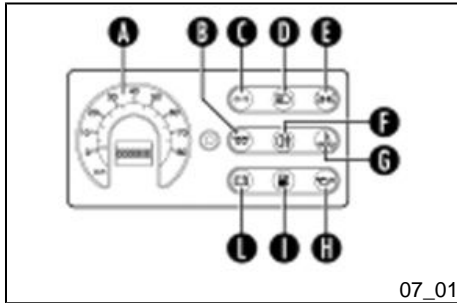

07_01

Instrument unit and indicators (07_01)

A = Speedometer, odometer/mileometre.

B = Preheat glow plug indicator (only on diesel versions - amber colour).

C = Flashing lights on indicator (green colour).

D = High beams on indicator (blue colour).

E = Taillights on indicator (green colour).

F = Rear fog light on indicator (amber colour).

G = High water temperature indicator (only on diesel versions - red colour).

H = Oil reserve indicator (for gasoline versions). Inadequate oil pressure indicator (for diesel versions).

I = Fuel reserve indicator (amber colour).

L = Battery charge voltage low indicator (red colour).

Ape TM - Ape TM Diesel



VEICOLI TRASPORTO LEGGERO



Chap. 08
Air control
system

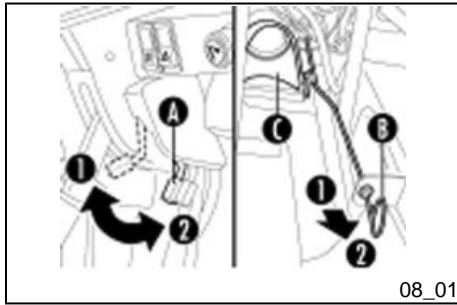

Heating (08_01)

Cabin heater controls (gasoline):

Lever «A» (with red grip): in position 1.

Control bar «B»: in position 1 (travel end back) located below the driver's seat to allow opening diaphragm «C».

Shuttering outlets «D» in position 1 (OPEN).

The cabin heater can be disabled by the shuttering outlets «D» or directly by returning lever «A» to neutral position (position 2).

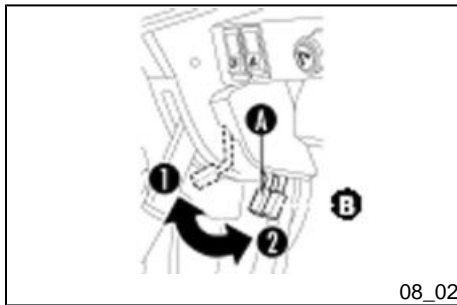

Heating (08_01, 08_02)

Cabin heating controls (diesel):

Lever «A» (with red grip): position 1, warm air.

Lever «B»: position 1, warm air towards feet.

Lever «B»: position 2, warm air towards the windscreen.

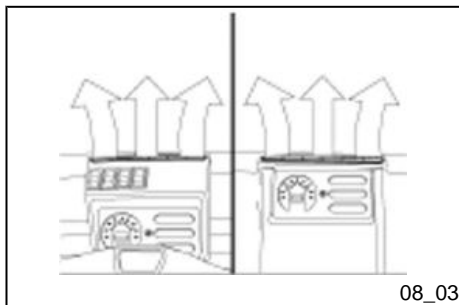

08_03

Heating and demisting (08_03)

Cabin defrosting/heating controls (gasoline):

Control bar «B» in position 2 (travel end forward).

Shuttering outlets «D» in position 1 (OPEN).

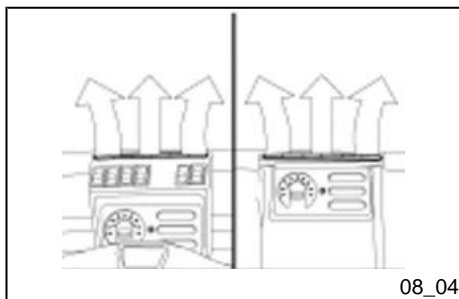

08_04

Heating and demisting (08_03, 08_04)

Cabin defrosting/heating controls (diesel):

Control bar «B» in position 2.

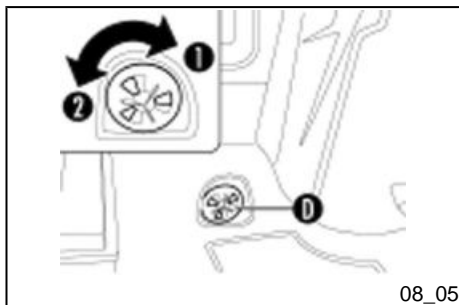

08_05

Demisting (08_05)

Cabin defrosting controls (gasoline):

Control bar «B» in position 2 (travel end forward).

Shuttering outlets «D» in position 2 (CLOSED).

The hot air flow is thus sent to the windscreen only, through the two outlets shown in the figure.

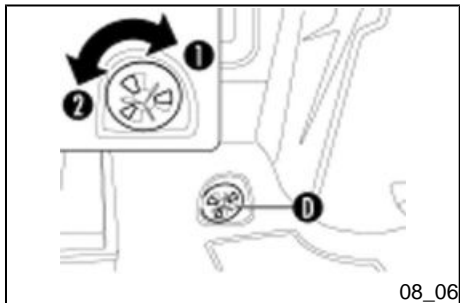

Demisting (08_05, 08_06)

Cabin heating controls (diesel):

Control lever «B» in position 1.

The hot air flow may be partitioned through the two outlets «D».

Ape TM - Ape TM Diesel



VEICOLI TRASPORTO LEGGERO



Chap. 09
Mirrors and
Window Glasses

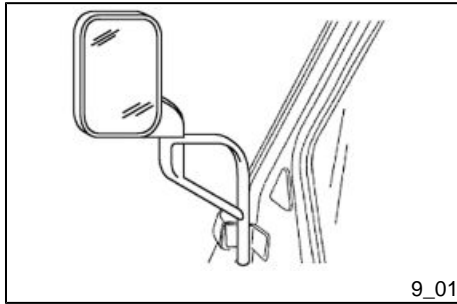

Adjusting the mirror (9_01)

Rear-view mirrors are adjusted by moving the mirror body manually until the ideal angle is obtained to guarantee full visibility.

CAUTION



NEVER ADJUST MIRRORS WHILE DRIVING AS YOU MAY LOSE CONTROL OF THE VEHICLE.

Wipers and Brushes (9_02, 9_03)

Blade

- Clean regularly the rubber part with specific products.
- Replace the blade if the rubber is misshapen or worn. In any case, blades should be replaced approximately once a year.

Some simple recommendations can minimise the possibility of damage to the blade:

- - If the temperature is below zero, make sure the rubber part is not frozen to the windscreen. If required, use a de-icing product to release the blade.
- - Remove any snow from the windscreen: this will protect the blade and avoid overloading and overheating the electric motor.
- Do not operate the windscreen wiper on a dry windscreen.



DRIVING WITH A WORN WINDSCREEN WIPER BLADE CAN BE EXTREMELY DANGEROUS AS VISIBILITY IS DECREASED IN POOR WEATHER CONDITIONS.

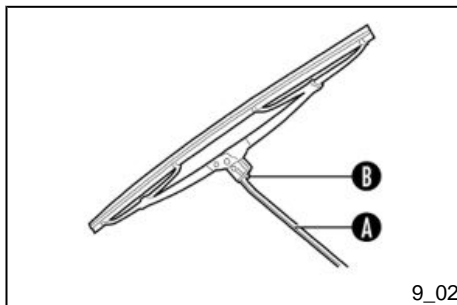

Replacing the windscreen wiper blade

Replace the windscreen wiper blade as follows:

- Lift the windscreen wiper arm "A" and position the blade so that it forms a right angle with the arm;
- Press retainer tab "B" of the latching spring and extract the blade for arm "A";
- Fit a new blade. Insert the tab in its seat on the arm. Make sure it is locked.

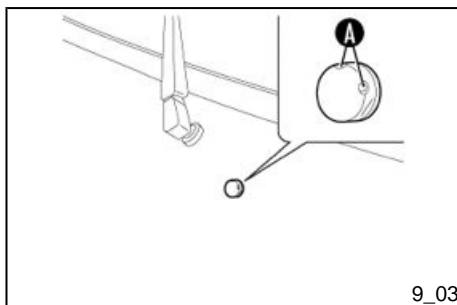

Nozzles

- If there is no jet of fluid, first of all check whether the windscreen washer reservoir is full.
- Check whether the holes «A» are clogged. If so, open them with a pin.
- Direct the windscreen washer nozzles so that the jets are directed towards the highest position of the blade stroke.

Ape TM - Ape TM Diesel



VEICOLI TRASPORTO LEGGERO



Chap. 10
Inside
equipment

Ape TM - Ape TM Diesel



VEICOLI TRASPORTO LEGGERO



Chap. 11
Electrical
system

Fuel version

The power for the lighting and indication system devices is provided in direct current by a dynamotor/battery unit, with a voltage regulator separated by the remote control switch unit, both installed under the seat in the compartment. The dynamotor acts as a generator-dynamo and as a starter motor: in particular, upon start-up, it absorbs current from the battery and operates as an electric motor.

After starting the engine and reaching a certain speed, the dynamotor acts as a normal dynamo, charging the battery and powering the vehicle system.

Electric characteristic

Battery

12V-32Ah

Diesel version

The power for the lighting and indication system devices is provided in direct current by a special battery.

The engine is equipped with an 18-pole rotor stator unit, three-phase, 330W MAX.

The preheating device for starting the engine, which is fitted with a light indicator, controls the special preheat glow plug.

FOR ESPECIALLY COLD AREAS, WE RECOMMEND INSTALLING A 12V-60AH BATTERY.

WHEN INTERVENING ON THE ELECTRICAL SYSTEM, MAKE ESPECIALLY SURE THAT THE WIRES LEADING TO THE ELECTRONIC CONTROL UNIT ARE CORRECTLY CONNECTED AND RESPECT THE COLOUR CODING GIVEN ON THE CONTROL UNIT.

Electric characteristic

Battery

12V-50Ah

Ape TM - Ape TM Diesel



VEICOLI TRASPORTO LEGGERO



Chap. 12
Emergency

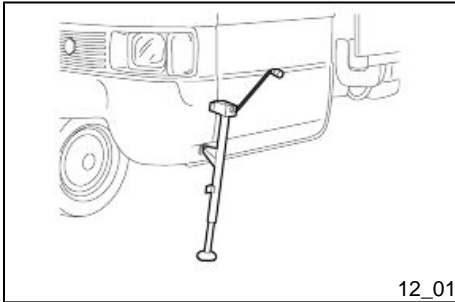

12_01

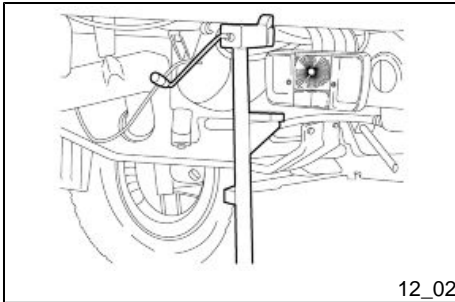

12_02

Wheel replacement (12_01, 12_02)

The tyre replacement operation and the use of jack require some precautions which are given below.

WARNING



SIGNAL THE PRESENCE OF THE VEHICLE AS PRESCRIBED BY THE HIGHWAY CODE IN FORCE.

PLACE THE JACK IN THE POSITIONS SHOWN SO AS NOT TO DAMAGE MECHANICAL PARTS OR THE BODY

WARNING



WHENEVER POSSIBLE, REPLACE TYRES WITH THE VEHICLE ON LEVEL GROUND. IF THE GROUND IS SLOPING OR BADLY SURFACED, PUT WEDGES OR ANY OTHER SUITABLE MATERIAL UNDER THE WHEELS TO BLOCK THE VEHICLE. DO NOT GREASE BOLT THREADS BEFORE REFITTING: THEY COULD COME UNDONE SPONTANEOUSLY.

NEVER TAMPER WITH THE INFLATION VALVE. DO NOT PLACE TOOLS BETWEEN RIM AND TYRE.

Maintenance instructions

They are located into the compartment, below the seat.

CAUTION

THE JACK CAN ONLY BE USED TO REPLACE THE WHEELS. NEVER USE THE JACK TO PERFORM REPAIRS UNDER THE VEHICLE. THE VEHICLE MAY FALL IF THE JACK IS NOT POSITIONED CORRECTLY

CAUTION

PERIODICALLY CHECK TYRE PRESSURE ACCORDING TO THE VALUES GIVEN IN THE: «MAINTENANCE

».

Ape TM - Ape TM Diesel



VEICOLI TRASPORTO LEGGERO



Chap. 13
Maintenance

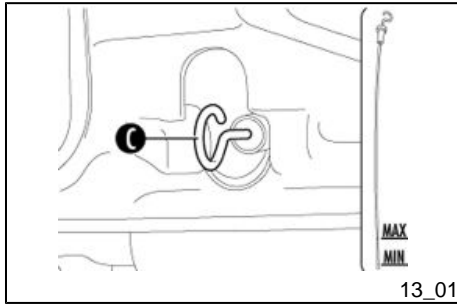

13_01

Check engine oil level (13_01)

Engine oil level check (diesel version)

To check the engine oil level, proceed as follows:

1. Check with engine off and vehicle on a flat surface;
2. Extract the level bar from the rear side of the vehicle and check that the level is between the **MIN** and **MAX** positions;
3. If a top up is required, add new oil by the filler located into the engine compartment;

WARNING



TOP UP USING OIL OF THE SAME TYPE ALREADY CONTAINED INTO THE ENGINE.

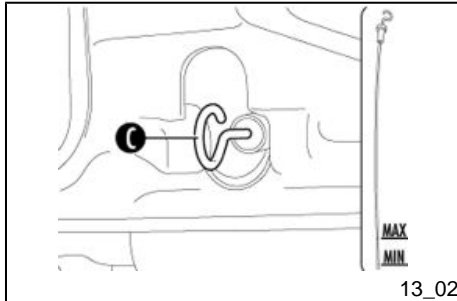

13_02

Oil change and oil filter replacement (13_02, 13_03, 13_04)

Replacing the engine oil (diesel version)

To replace the engine oil proceed as follows:

1. Loosen the drainage cap «**A**» and drain the oil;
2. When drainage is complete, tighten cap «**A**», remove cap «**B**» and pour new oil by the filler; the oil level must always be between the **MIN** and **MAX** positions marked on bar «**C**»;
3. Periodically check the oil level;

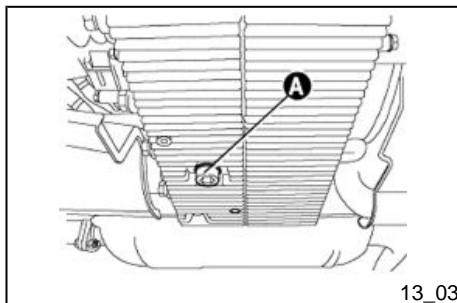

13_03

WARNING

REPLACE THE OIL WHEN THE ENGINE IS WARM.

CAUTION

RUNNING THE ENGINE WITH INSUFFICIENT LUBRICATION OR IMPROPER LUBRICANTS ACCELERATES THE WEAR OF ALL MOVING PARTS AND MAY RESULT IN SERIOUS DAMAGES.

CAUTION

USED OIL IS HARMFUL TO THE ENVIRONMENT. WHEN REPLACING THE OIL, WE SUGGEST TO CONTACT A PIAGGIO AUTHORISED SERVICE POINTS EQUIPPED FOR DISPOSING SPENT OILS IN THE RESPECT OF NATURE AND IN COMPLIANCE WITH THE LAWS IN FORCE.

Characteristic

new oil:

2.8 litres

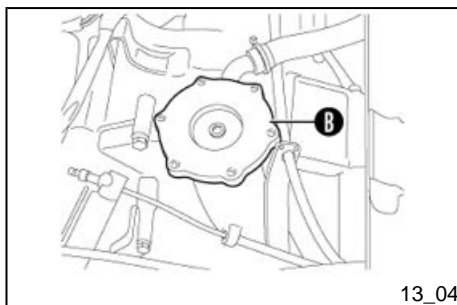

13_04

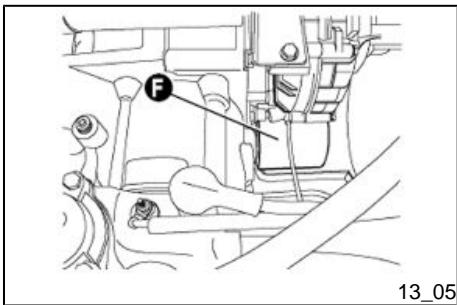

Oil change and oil filter replacement (13_04, 13_05)

Engine oil cartridge replacement (Diesel version)

To gain access to the oil cartridge proceed as follows:

1. Remove the engine inspection door (or lift the metal alloy plate);
2. Drain the engine crankcase;
3. Remove the filtering body «F»;
4. Lubricate the new cartridge seal and screw it in as far as it will go, and then tighten it by hand by half a turn;
5. Fill up with fresh oil, then start the engine whilst inspecting for oil leaks.

WARNING



TO PREVENT DAMAGING THE ENGINE, FILL THE FILTER WITH NEW OIL BEFORE PROCEEDING TO THE REASSEMBLY.

IN CASE OF REPLACEMENT OF THE FILTER, THE AMOUNT OF OIL CONTAINED INTO THE CRANKCASE IS OF ABOUT 2.8 LITRES (THE TOTAL CIRCUIT CAPACITY IS 3.5 LITRES).

WARNING



USING NON-ORIGINAL SPARES SERIOUSLY IMPAIRS THE VEHICLE PERFORMANCE AND LIFE.

WARNING

TO DISPOSE OF OLD FILTERS, TURN TO A PIAGGIO SERVICE CENTRE. FOLLOW THE SPECIFIC ENVIRONMENT-RELATED REGULATIONS IN FORCE.

Checking the brake fluid level (13_06)

Checking level (gasoline version)

The rear brake fluid tank is located into the driver compartment, above the brake pedal. Check the level as follows:

1. Stop the vehicle on level ground;
2. Check the oil level is between 1 cm under the surface of cap «A» (**MAX** level) and 1 cm over the bottom of the reservoir (**MIN** level).

If the oil is under the minimum level contact a **PIAGGIO Dealer or Authorised Service Centre** to have the brake system checked.

Topping up brake fluid

To fill the reservoir, unscrew cap «A» and top up.

In normal climates, replace the fluid every 20,000 km or every 2 years.

Qualified and skilled personnel is required for this operation. We recommend you go to a **PIAGGIO Dealer or Authorised Service Centre**.

Recommended products

AGIP DOT4 BRAKE FLUID

Brake fluid

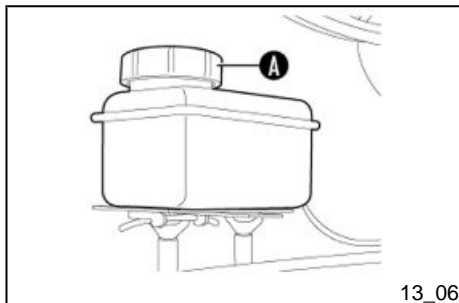

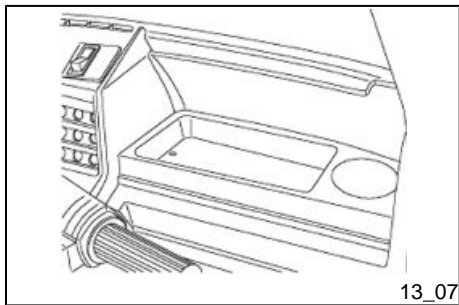

Checking the brake fluid level (13_06, 13_07)

Level check (Diesel version)

The rear brake fluid reservoir is located inside the vehicle, underneath the cover on the right-hand side of the instrument panel.

To check the level, remove the two fixing screws and the cover, then follow the procedure outlined in the previous paragraph.

CAUTION



ONLY USE DOT 4 CLASSIFIED BRAKE FLUIDS.

CAUTION



BRAKE FLUID IS HAZARDOUS: WASH WITH WATER IN THE EVENT OF ACCIDENTAL CONTACT.

CAUTION



BRAKING CIRCUIT FLUID IS VERY CORROSIVE; AVOID CONTACT WITH PAINTED PARTS.



THE BRAKING CIRCUIT FLUID IS HYGROSCOPIC, I.E., IT ABSORBS HUMIDITY FROM THE SURROUNDING AIR. IF THE HUMIDITY IN THE BRAKE FLUID EX-

CEEDS A CERTAIN VALUE, IT WILL LEAD TO INEFFICIENT BRAKING. NEVER USE BRAKE FLUID FROM PREVIOUSLY OPENED OR PARTLY-EMPTY CONTAINERS.

Gear box oil level (13_08, 13_09, 13_10)

To check the gearbox oil, proceed as follows:

1. Check with engine off and vehicle on a flat surface;
2. Loosen the two screws fixing the SAS to the support bracket and move the SAS so as to access the cap «A»;
3. Loosen the inspection cap «A», then check that the oil level is between the **MIN** and **MAX** references on the bar contained into the cap;
4. If you need to top up the level, extract the cap with the bar and restore the level;
5. Replace the SAS to the original position.

TOP UP USING OIL OF THE SAME TYPE ALREADY CONTAINED INTO THE GEARBOX.

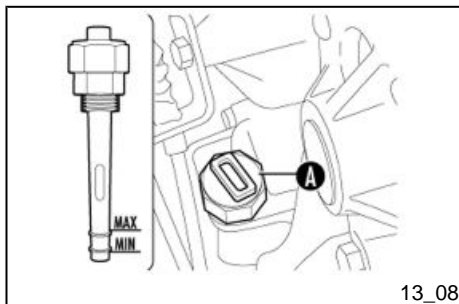

13_08

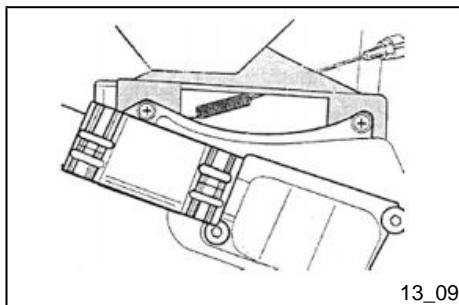

13_09

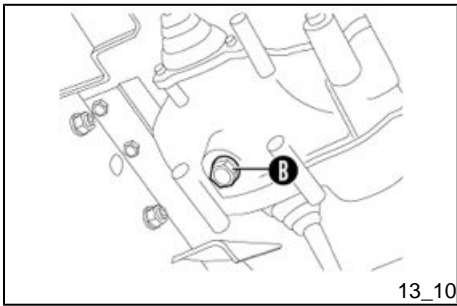

13_10

To replace the gearbox oil proceed as follows:

1. Remove the cap «A», loosen cap «B» and drain the oil; when drainage is complete, replace cap «B».
2. Pour some oil into the top hole and let the engine run for a few seconds; then, drain the crankcase again.
3. Refill with new oil, periodically checking the level with the bar until the mark MAX is reached.

WARNING



REPLACE THE OIL WHEN THE ENGINE IS WARM.

- **AN EXCESSIVE AMOUNT OF OIL CAN SPILL OUT AND DIRTY THE ENGINE.**

WARNING



- **USED OIL CONTAINS SUBSTANCES HARMFUL TO THE ENVIRONMENT. FOR OIL REPLACEMENT, CONTACT ANY AUTHORISED PIAGGIO SERVICE CENTRE AS THEY ARE EQUIPPED WITH LAW-ABIDING ENVIRONMENTALLY- FRIENDLY OIL DISPOSAL SYSTEMS**

Recommended products

AGIP ROTRA MP 80W-90

Oil with specifications SAE 80W-90, API GL-5
Gearbox oil

Characteristic

Oil amount for gasoline version:

885 grams (approx. 1000 cm3)

Window washer fluid level (13_11)

Topping up windscreen washer fluid

The windscreen washer fluid reservoir is located inside the cab on the front right panel.

To fill the reservoir, unscrew cap «A» and top up. Use a specific detergent.

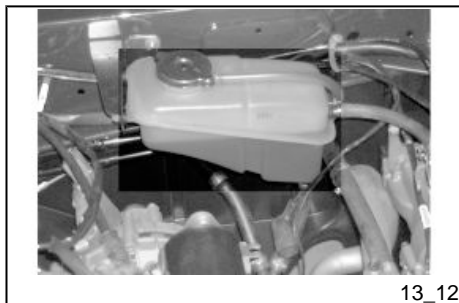
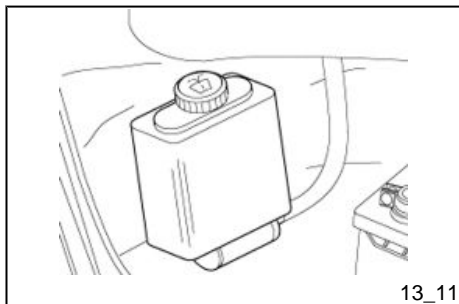

Cooled fluid (13_12)

Coolant top-ups (Diesel version)

Loosen the filler cap on the expansion tank.

Fill up the tank with coolant (permanent 50% water + ethyl glycol fluid recommended).

The correct level is indicated on the expansion tank by the **LEVEL** reference mark.

Circuit air-bleed: start the engine up and let it run at idle so to allow for any air bubble trapped inside the circuit to leave the cooling system.

The coolant level will gradually decrease and then settle. Stop the engine and top-up the circuit as explained in the previous paragraph. After a few hours of normal use, check the level with the engine cold.

Cooling circuit hose inspection (every 10,000 Km)

Check the coolant circuit hoses for signs of wear (alligating of the rubber) and also check that all fittings are properly sealed. If any of the hoses is worn, please contact your nearest **Authorised Piaggio Service Centre** to have it replaced.

Changing the engine cooling fluid

Drain the circuit completely and refill following the procedure given in the previous paragraphs.

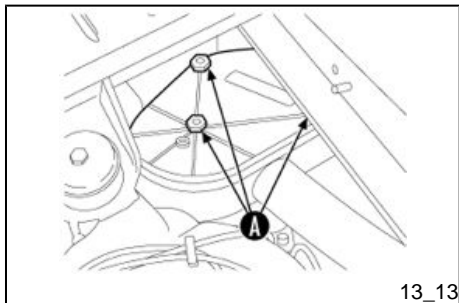

Checking and replacing the air cleaner element (13_13, 13_14)

Replacing the air filter (gasoline version)

To replace the air filter, proceed as follows:

1. Lower the rear side and remove the engine cover;
2. Loosen the three knobs «A» fixing the filter cover, then remove the cover;
3. Remove the filtering element «B»;
4. Replace the filtering element and refit the cover.

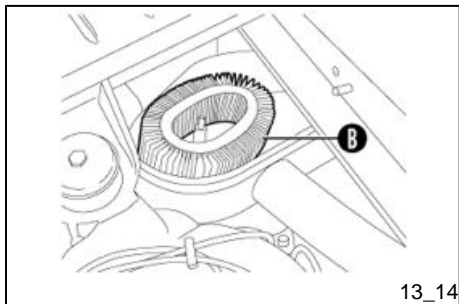

Checking and replacing the air cleaner element (13_14, 13_15, 13_16)

Replacing the air filter (diesel version)

To replace the air filter, proceed as follows:

1. Loosen the fixing knob «A» and remove the filter box cover «B»;
2. Extract the filtering element «C» and replace it with a new one;
3. Refit the cover and tighten the knob «A».

CAUTION

THE FILTERING ELEMENT MUST BE REPOSITIONED INSIDE THE AIR-BOX PROPERLY, FOLLOWING THE REMOVAL OPERATIONS BUT IN REVERSE ORDER.

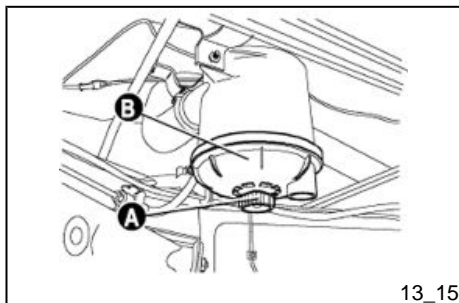

13_15

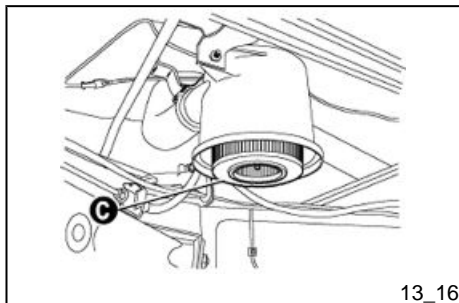

13_16

Replacing the fuel filter (13_17)

Replacing the diesel filter

The diesel filter «A» can be removed by turning it anticlockwise.

At the bottom of the cartridge there is the screw «B» for draining condensation water.

To drain the condensation water, loosen the screw «B»; tighten it again when diesel without water comes out.

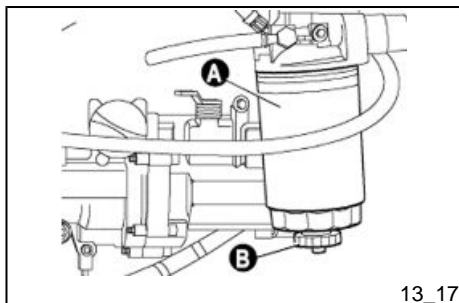

13_17

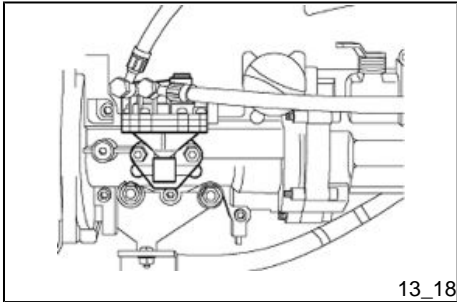

13_18

Air bleeding (13_18)

Bleed air once the injection system has been emptied for checking due to running out of fuel.

To this purpose, repeatedly actuate the lever controlling the hand pump, until you feel a resistance during the pumping phase.

Normally, a totally empty system is filled with about 40 pumping actions.

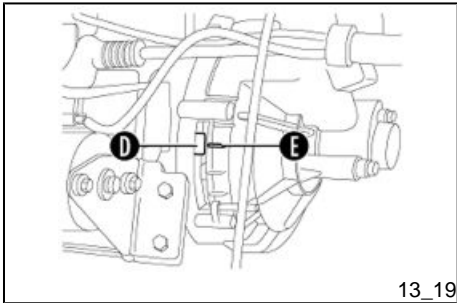

13_19

Fuel exhaustion (13_19)

Running out of fuel (diesel version)

If you run out of fuel, refuel and then actuate the lever controlling the hand pump, as described for the air bleeding, until you feel a certain resistance during the pumping phase.

Then, start the engine according to the standard procedure.

If you feel a certain resistance in the pumping and the stroke of the hand pump control lever is not complete, turn the driving shaft by another revolution to return the mark «D» at the reference «E».

Actuate the hand pump again until the injection system is totally bled.

N.B.

IN CASE OF AIR BLEEDING AND OF RUNNING OUT OF FUEL, IN ORDER TO OBTAIN THE MAXIMUM CAPACITY OF THE HAND PUMP IT IS NECESSARY TO TURN THE DRIVING SHAFT UNTIL THE MARK «D» PUNCHED ON THE CLUTCH BOX MATCHES THE REFERENCE «E» (TDC) OF THE CRANKCASE.

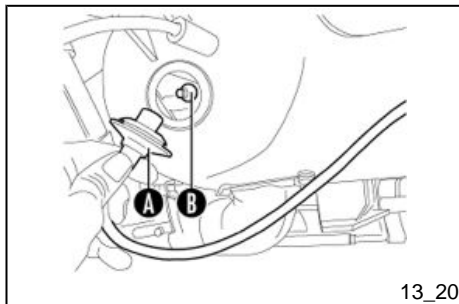

Checking and replacing the pre-heating plugs (13_20)

Access the spark plugs as follows:

1. remove the plate releasing the three fixing clamps;
2. disconnect the high voltage wire cap «A» from the spark plug «B»;
3. remove the spark plug using the provided tool;
4. when refitting, place the spark plug in place at the correct slant and screw it by hand. Use the tool for locking only;
5. insert cap «A» fully on the spark plug and refit the rear washer.



THE SPARK PLUG SHOULD BE REMOVED ONLY WHEN THE ENGINE IS COLD. CHANGE THE SPARK PLUG EVERY 4,000 KM. USING SPARK PLUGS WITH DIFFERENT VALUE WITH RESPECT TO THE PRESCRIPTIONS OR WITH INCORRECT THREADING CAN SEVERELY DAMAGE THE ENGINE.

Characteristic

Recommended spark plugs:

BOSCH W3AC

CHAMPION RL78C

NGK BR8HS

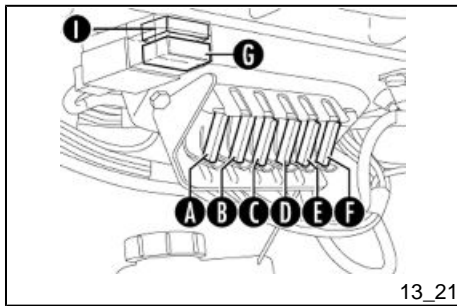

13_21

Fuses (13_21, 13_22, 13_23)

The electrical system is protected by six 8A fuses located underneath the instrument panel, to the left of the steering column.

To the left of the fuse-box are two fuses: 15A fuse «G» protecting the cigarette lighter, and 15A fuse «I» guarding the heater fan.

Van versions are also fitted with an 8A fuse located underneath the right-hand side seat and protecting the van lighting circuit.

The vehicle is also protected by the main fuse «H» located underneath the passenger seat.

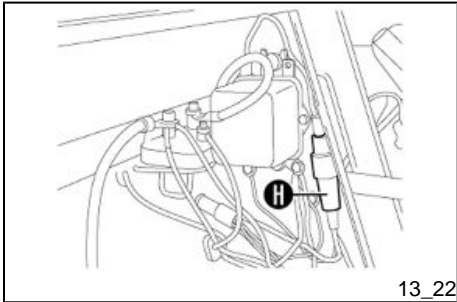

13_22

The function of general fuse «H» varies according to the version:

- Gasoline = 40 A Safeguarding all services with the exception of the start-up power circuit.
- Diesel = 40 A Safeguarding the preheating and charging circuits.

Next to the main fuse, on the tipper version, is an additional 80A fuse safeguarding the body tilting system.

The six 8 A fuses safeguard different circuits depending on the vehicle's version.



BEFORE REPLACING THE BLOWN FUSE, TRY TO ELIMINATE THE FAULT THAT CAUSED IT TO BLOW. NEVER ATTEMPT TO REPLACE A FUSE USING A DIFFERENT MATERIAL (I.E. A PIECE OF ELECTRIC WIRE) OR A HIGHER AMP FUSE.

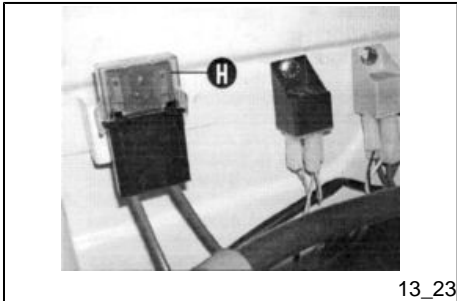

13_23



IF YOU WANT TO FIT ADDITIONAL UNITS ON THE VEHICLE (E.G. ADDITIONAL LIGHTS) WE POINT OUT THAT INCORRECT DERIVATIONS ON THE ELECTRIC CONNECTIONS MAY CAUSE DAMAGE TO THE INSTALLATION.

Handlebar gasoline version

- A. Dipped beams (left and right), rear fog light circuit.
- B. High beams (left and right), high beams indicator.
- C. Emergency (key **OFF**), windscreen wiper, horn, glass bowl.
- D. Emergency (key **ON**), flashing lights, indicator circuits (recharge, oil reserve, fuel reserve, tilting), stop lights, reverse gear lights.
- E. Instrument lighting, light indicator, number plate lighting, taillights (left rear and front), cigar lighter lighting.
- F. Taillights (right rear and front).

Steering wheel gasoline version

- A. Emergency (key **OFF**), windscreen wiper, horn, glass bowl.
- B. Emergency (key **ON**), flashing lights, indicator circuits (recharge, oil reserve, fuel reserve, tilting), stop lights, reverse gear lights.
- C. Right dipped beam.
- D. Left dipped beam, rear fog light circuit.
- E. Instrument lighting, light indicator, number plate lighting, taillights (left rear and front), cigar lighter lighting.
- F. Taillights (right rear and front).

Handlebar diesel version

- A. Emergency (key **OFF**), windscreen wiper, horn, glass bowl.
- B. Emergency (key **ON**), flashing lights, indicator circuits (recharge, oil pressure, oil temperature, fuel reserve, preheating, tilting), stop lights, reverse gear lights, solenoid valve, preheating (power circuit excluded).
- C. Right dipped beam.
- D. Left dipped beam, rear fog light circuit.
- E. Instrument lighting, light indicator, number plate lighting, taillights (left rear and front), cigarette lighter lighting.
- F. Taillights (right rear and front).

Handlebar diesel version

- A. Dipped beams (left and right), rear fog light circuit.
- B. High beams (left and right), high beams indicator.
- C. Emergency (key **OFF**), windscreen wiper, horn, glass bowl.
- D. Emergency (key **ON**), flashing lights, indicator circuits (recharge, oil pressure, oil temperature, fuel reserve, tilting, preheating), stop lights, reverse gear lights.
- E. Instrument lighting, light indicator, number plate lighting, taillights (left rear and front), cigarette lighter lighting.
- F. Taillights (right rear and front).

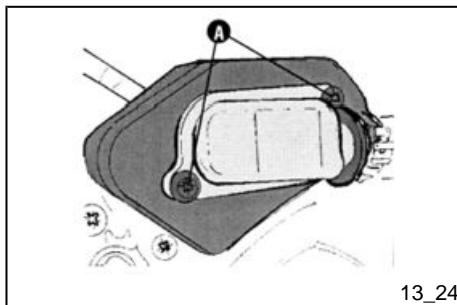

Exhaust circulation system (EGR) (13_24)

Secondary air box - SAS (gasoline version)

Remove the two screws «A» of the aluminium SAS cover, without extracting the metal pipe from the cover/sleeve. Remove the plastic cover and the plate, pull the sponge out and wash with soap and water.

Dry with compressed air before reassembling. Reinstall the plate into the seat on the two plastic and aluminium covers.

Replace the box sealing O-Ring housed in the cover seat at every disassembly.



TURN TO AN AUTHORISED PIAGGIO SERVICE CENTRE FOR THIS OPERATION.

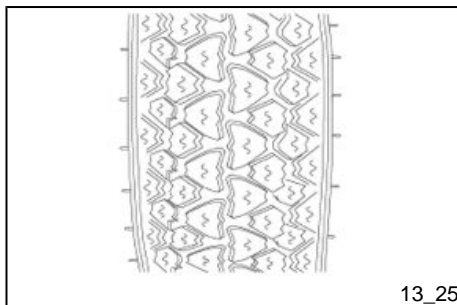

Tyres (13_25)

- Periodically check the inflation pressure of each tyre.
- Tyres feature wear indicators; replace tyres as soon as these indicators become visible on the tyre tread.
- Also check that there are no cuts on the sides of the tyres or irregular tread wear; in such cases, contact an **authorised service centre** for the replacement.

Characteristic

TYRES

4.50 - 10"

TYRE PRESSURE

Front tyre pressure	2.5 atm
Rear tyre pressure	4.5 atm

Pressure

ACCORDING TO THE PROVISIONS OF THE REGULATIONS IN FORCE, THE TYRE TREADS MUST BE OVER 1.6 MM THICK.



CHECK TYRE PRESSURE WHEN COLD. INCORRECT TYRE INFLATION PRESSURE WILL CAUSE UNEVEN THREAD WEAR AND MAKE DRIVING DANGEROUS. THE TYRE MUST BE REPLACED WHEN THE TREAD REACHES THE WEAR LIMITS SET FORTH BY LAW.

Periods of inactivity

Prolonged inactivity

If the vehicle is not to be used for long periods, the battery must be charged periodically (when not in use, the battery will discharge over a period of about three months). If the battery is removed, make sure you connect the leads correctly at the time of installation

Perform the following operations:

1. Clean the vehicle;

2. Remove the air filter and close the intake and exhaust ducts;
3. Lift the vehicle from the ground, resting the wheels on wooden supports;
4. Drain the fuel tank. Cover the unpainted metal parts with rustproof grease;
5. For the battery, follow the procedures indicated in the «**Maintenance**» section.

FOR THE GASOLINE VERSION WITH ENGINE ON AND AT LOW SPEED, POUR 30 CC OF SAE 40 OIL THROUGH THE CARBURETTOR CHOKE.

NO START-UP (GASOLINE VERSION)

Connectors to the spark plug disconnected	Restore connection
---	--------------------

DIFFICULTIES WHEN STARTING (GASOLINE VERSION)

Fuel tank empty	Refuel
Clogged or dirty filters, jets or carburettor	Contact an Authorised PIAGGIO Service Centre
Starter control lever in lowered position	Move it to lifted position

DIFFICULTIES WHEN STARTING (DIESEL VERSION)

Connectors to the glow plug disconnected, or inefficient glow plug	Restore the connection or replace the preheating glow plug
No fuel in tank	Refuel
Air into the injection system	Bleed the air
Water in the diesel	Drain the water and replace the filter, if required, then bleed the air
Injector dirty or faulty	Contact an Authorised PIAGGIO Service Centre

IGNITION FAILURE (GASOLINE VERSION)

No spark on spark plug	<p>Check whether the electrodes are clean (clean with white spirit and wire brush or sandpaper).</p> <p>Check spark plug insulation: if cracked or broken, replace the spark plug. If the spark plug is in good conditions, contact an Authorised PIAGGIO Service Centre.</p>
------------------------	--

CAUSE: HIGH VOLTAGE. THIS INSPECTION SHOULD BE CARRIED OUT BY A SKILLED MECHANIC.

POOR COMPRESSION (GASOLINE VERSION)

Spark plug seat threading damaged; head bolts insufficiently torqued, piston seals worn	Contact an Authorised PIAGGIO Service Centre
---	---

HIGH FUEL CONSUMPTION AND POOR PERFORMANCE (GASOLINE VERSION)

Air filter blocked or dirty	Replace the air filter
-----------------------------	------------------------

ENGINE IRREGULAR OPERATION (DIESEL VERSION)

Injector faulty	Contact an Authorised PIAGGIO Service Centre
-----------------	---

Air into the injection system	Bleed the air
-------------------------------	---------------

Diesel filter clogged	Replace the filter and bleed the air
-----------------------	--------------------------------------

POOR PERFORMANCE (DIESEL VERSION)

Injector faulty	Contact an Authorised PIAGGIO Service Centre
-----------------	---

Diesel filter clogged	Replace the filter and bleed the air
-----------------------	--------------------------------------

WHITE FUMES UPON EXHAUST (DIESEL VERSION)

Injector faulty	Contact an Authorised PIAGGIO Service Centre
Delayed injection	Contact an Authorised PIAGGIO Service Centre

BLACK FUMES UPON EXHAUST (DIESEL VERSION)

Air filter clogged	Replace the air filter
Wrong injection pump calibration	Contact an Authorised PIAGGIO Service Centre
Injector faulty	Contact an Authorised PIAGGIO Service Centre

THE ENGINE KNOCKS

Injection advanced	Contact an Authorised PIAGGIO Service Centre
Injector faulty	Contact an Authorised PIAGGIO Service Centre

POOR SUSPENSION

Oil leaks or inadequate spring loading; stroke end bumpers worn.	Contact an Authorised PIAGGIO Service Centre
--	---

TRANSMISSION IS NOT SMOOTH

Gearbox failure	Contact an Authorised PIAGGIO Service Centre
-----------------	---

Gearcase noise	Contact an Authorised PIAGGIO Service Centre
----------------	---

POOR BRAKING ACTION

Drums greasy, brake shoes worn	Contact an Authorised PIAGGIO Service Centre
--------------------------------	---

Air into the circuit pipes	Bleed the air
----------------------------	---------------

Shoe self-adjustment device faulty	Contact an Authorised PIAGGIO Service Centre
------------------------------------	---

Irregular friction material wear	Contact an Authorised PIAGGIO Service Centre
----------------------------------	---

Oil leaks from the circuit	Contact an Authorised PIAGGIO Service Centre
----------------------------	---

Air in the brake circuit	Bleed the air Contact an authorised PIAGGIO service centre.
--------------------------	---

ELECTRIC SYSTEM INEFFICIENCY

Faulty controls (switches) or lights and indicators	Contact an Authorised PIAGGIO Service Centre
---	---

Battery inefficient	Contact an Authorised PIAGGIO Service Centre
---------------------	---

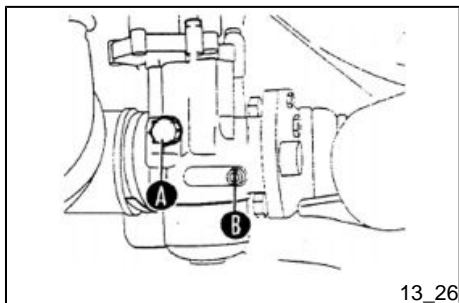

Troubleshooting / What to do if... (13_26)

Idle adjustment

Adjust the idle speed as follows:

1. Release the three clamps and remove the plate.
2. Start the engine and take it to its normal operating temperature, i.e., 5 minutes run at a medium speed.
3. Turn the gas valve travel end adjustment knob «A» to approach the minimum stop limit of engine spontaneous stop.
4. Then, adjust the mixture flow adjustment screw «B» to reach the highest rpm number. If the rpm number reached is excessive, decrease it by knob «A» to reach a regular minimum speed.

If this is problematic, go to a **PIAGGIO Dealer or Authorised Service Centre**.



THE IDLE ADJUSTMENT MUST BE PERFORMED WITH HOT ENGINE AND ACTIVE CATALYTIC CONVERTER. BEFORE PROCEEDING, CHECK THAT THERE IS NO PLAY ON THE THROTTLE CONTROL. IF REQUIRED, GO TO A PIAGGIO DEALER OR AUTHORISED SERVICE CENTRE TO HAVE THE THROTTLE CONTROL PLAY ADJUSTED.

CAUTION

IN CASE OF PROBLEMS WHEN ADJUSTING THE IDLE SPEED, IT MAY BE NECESSARY TO ADJUST EXHAUST EMISSIONS (CO). THIS OPERATION MUST BE PERFORMED AT AN AUTHORISED PIAGGIO SERVICE CENTRE.

Characteristic**Idle adjustment**

(approx. 1250 - 1450 rpm)

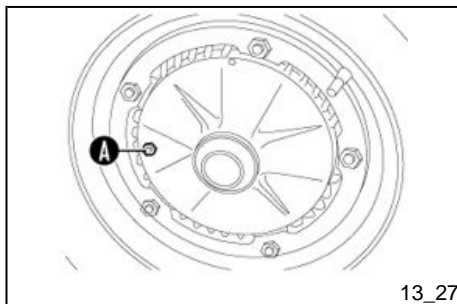

13_27

Troubleshooting / What to do if... (13_26, 13_27)**Brakes adjustment**

The brake shoes are provided with a self-adjustment device that automatically restores the proper clearance between blocks and drums, regardless of the friction material wear, so it is not necessary to perform manual adjustments.

The brake drums are provided with hole with screw cap «A» through which it is possible to inspect the wear of the friction material: In case of excessive wear, replace the brake shoes. For this operation, turn to a **Concessionaire or to an Authorised PIAGGIO Service Centre.**

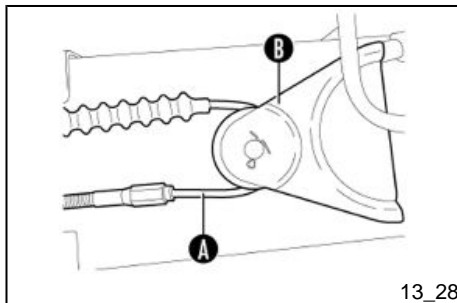

13_28

Troubleshooting / What to do if... (13_27, 13_28)**Parking brake**

Pull the lever to engage parking brake. Lift the lever slightly to release the brake, press the button with the thumb and lower the lever completely.



- **BEFORE SETTING OFF ENSURE THE PARKING BRAKE IS FULLY RELEASED AND THE WARNING LIGHT IS OFF. SHOULD THE PARKING BRAKE BE PARTIALLY PULLED, THIS WOULD CAUSE THE BRAKES**

TO OVERHEAT RESULTING IN LOSS OF BRAKING EFFICIENCY AND EARLY WEAR OF THE FRICTION MATERIAL.



WHEN PARKING THE VEHICLE ON HILL ROADS, ALWAYS PULL THE PARKING BRAKE LEVER FULLY AND MOVE INTO THE LOWEST GEAR OPPOSITE THE DIRECTION FACED BY THE VEHICLE. IN ADDITION, POSITION WEDGES BEHIND THE WHEELS.



- **TO IMPROVE SAFETY AND AVOID ACCIDENTAL ACTIVATIONS, WE SUGGEST YOU ALWAYS PULL THE PARKING BRAKE BEFORE, OPERATING THE LIFTING/LOWERING BODY CONTROL.**

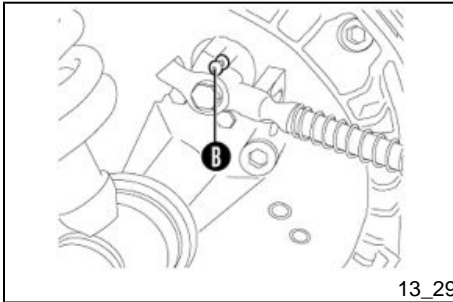

Troubleshooting / What to do if... (13_28, 13_29)

Air bleeding from the braking system

In case of anomalies of the brake performance, accompanied by idle pumping, have the system drained by the **Concessionaires or Authorised PIAGGIO Service Centres**.

IN FACT, THE BRAKE FLUID IS HIGHLY CORROSIVE AND IT MUST BE DISPOSED ACCORDING TO PRECISE REGULATIONS. MOREOVER, ANY INTERVENTION TO THE BRAKING SYSTEM MUST BE CARRIED OUT ONLY BY QUALIFIED PERSONNEL.

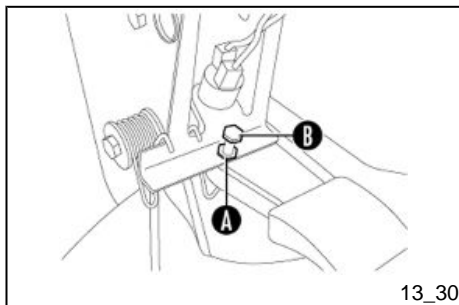

Troubleshooting / What to do if... (13_29, 13_30)

Brake pedal adjustment (steering wheel version)

Adjust the brake pedal stroke as follows:

1. Remove the nut «A» locking the adjustment screw «B».
2. Adjust the stroke by means of screw «B»;
3. Tighten the fastening nut «A».

For correct operation of the hydraulic brake system, the pedal should always have a slight play on the brake cylinder.



BRAKING ACTION MUST START AT THE BEGINNING OF THE BRAKE LEVER STROKE.

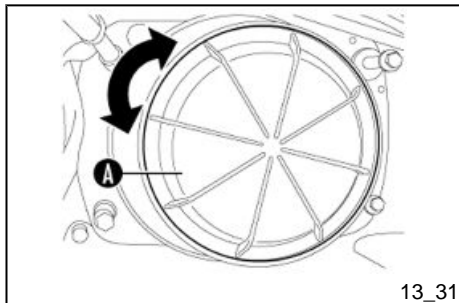

Troubleshooting / What to do if... (13_30, 13_31, 13_32)

Replacing the headlights

Replace the headlight bulb as follows:

1. Remove the headlight cover «A» turning it counter clockwise.
2. Release the two clips «B» fixing the lamp holders.
3. Extract the lamp holder «C» and replace the blown bulb «D».
4. Install the cover «A» inserting the 4 teeth «E» into the special slots and turn clockwise.

N.B.

TO REPLACE THE TAILLIGHT BULBS, FOLLOW THE INDICATIONS DESCRIBED FOR REPLACING THE HEADLIGHT BULB.

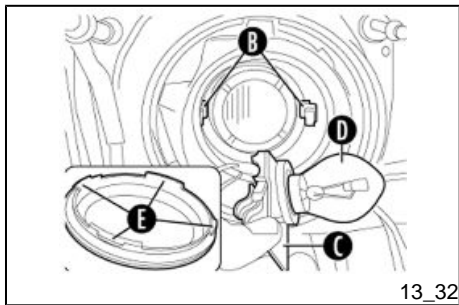

Troubleshooting / What to do if... (13_32, 13_33)

Front turn indicators

Replace the front turn indicator bulbs as follows:

1. Remove the plastic lens by removing the two screws «A»;
2. Extract the flashing light bulbs «B» pressing them and turning them clockwise.

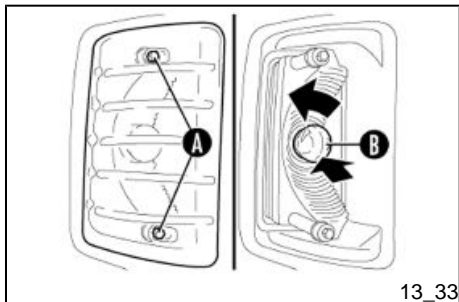

Troubleshooting / What to do if... (13_33, 13_34)

Rear lights

To replace the turn indicator lights, the stop lights, the taillights, the reverse gear and the rear fog light bulbs, proceed as follows:

1. Remove the plastic lens by removing the two screws «A»;
2. Extract the bulbs pressing them and turning them clockwise.

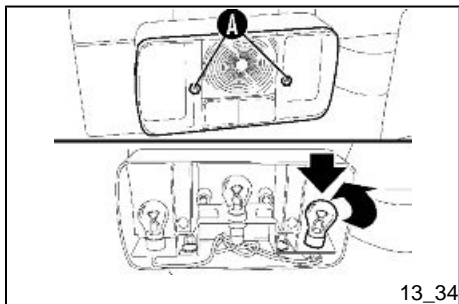



13_35

Troubleshooting / What to do if... (13_34, 13_35)

Number plate light

In order to remove the number plate light bulb, proceed as follows:

1. Remove the screw «A» fixing the bulb cover.
2. Replace the bulb and reassemble.

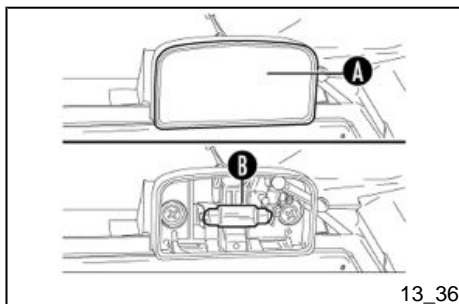

13_36

Troubleshooting / What to do if... (13_35, 13_36)

Front ceiling light

The cabin is provided with a courtesy light located above the internal rear-view mirror, whose switch is located on the glass bowl.

To replace bulb «B», remove snap-on lens «A» by hand.

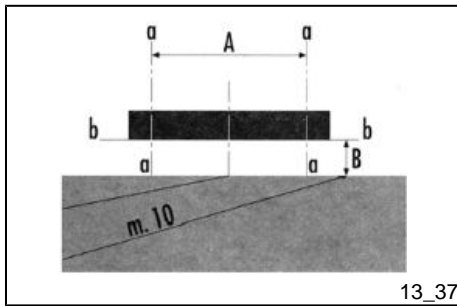

13_37

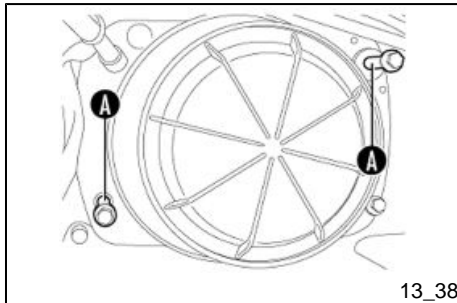

13_38

Troubleshooting / What to do if... (13_36, 13_37, 13_38)

Headlights adjustment

Proceed as follows:

1. Place the vehicle in conditions of use, without load, with the tyres inflated as prescribed, on flat ground at 10 m from a white screen in the shade. Make sure the vehicle axis is perpendicular to the screen;
2. Draw two vertical lines «a-a» at a distance «A» corresponding to the distance between headlight axes. Draw a horizontal line «b-b» at height «B» from ground corresponding to the headlight centre height from ground multiplied by 0.9;
3. Start the engine and lock the throttle twist grip at approximately 1/3 of its travel. Switch the dipped beam headlight on. Direct the beam so that the horizontal line between the light and the shade falls above the horizontal line «b-b» drawn on the screen;
4. If this is not so, adjust the headlight by means of the two screws «A» to correct any beam alterations.

CAUTION



THE ADJUSTMENT OF THE HEADLIGHTS ORIENTATION IS AN OPERATION THAT, IF NOT PERFORMED PROPERLY, INFRINGES ON A SPECIFIC RULE OF THE ROAD CIRCULATION CODE. FOR CHECKING AND ADJUSTING THE AIM OF THE HEADLIGHTS, WE SUGGEST TO CONTACT A PIAGGIO DEALER OR AUTHORISED SERVICE CENTRE.

CAUTION



BEFORE CARRYING OUT THE OPERATION FOR HEADLIGHTS AIMING, CHECK THAT THE TYRES ARE INFLATED TO THE INDICATED PRESSURES.

Troubleshooting / What to do if... (13_38)

Wheel replacement

Replace the wheel as follows:

1. Stop the vehicle so that it is not a hazard for oncoming traffic and so you can replace the wheel safely. The ground should be flat and adequately compact;
2. Pull the hand brake and engage the first gear.
3. Loosen the 5 nuts of the wheel to replace using the supplied wrench.
4. Apply the jack to the special stiffening triangles and lift the vehicle by a few centimetres.
5. Remove the nuts and extract the wheel.
6. Install the wheel, gradually tightening the nuts, and then lower the vehicle and tighten them thoroughly.

Ape TM - Ape TM Diesel



VEICOLI TRASPORTO LEGGERO



Chap. 14
Spare parts and
accessories

Warnings



WE RECOMMEND THE USE OF "ORIGINAL PIAGGIO SPARE PARTS", THE ONLY ONES TO OFFER THE SAME GUARANTEE OF QUALITY AS THE ORIGINAL PARTS INSTALLED ON THE VEHICLE. REMEMBER THAT THE USE OF NON-ORIGINAL SPARE PARTS WILL AFFECT YOUR RIGHTS AND INVALIDATE THE TERMS OF THE GUARANTEE

WARNING



PIAGGIO MARKETS ITS OWN LINE OF ACCESSORIES, WHICH ARE COVERED BY A MANUFACTURER'S WARRANTY ON THE BASIS OF THEIR USE. IT IS THEREFORE INDISPENSABLE TO TURN TO AN AUTHORISED PIAGGIO DEALER OR SERVICE CENTRE IN ORDER TO SELECT THEM AND HAVE THEM CORRECTLY ASSEMBLED. USING NON-ORIGINAL SPARE PARTS CAN AFFECT THE VEHICLE STABILITY AND PERFORMANCE, WITH CONSEQUENT DRIVING HAZARDS AND DRIVER SAFETY HAZARDS.

Ape TM - Ape TM Diesel



VEICOLI TRASPORTO LEGGERO



Chap. 15
TIPPER Version

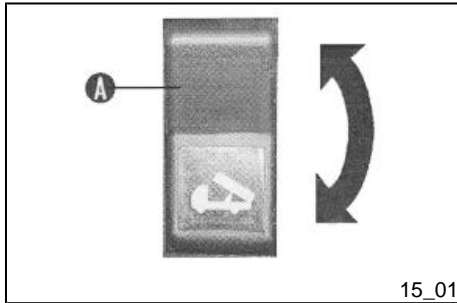

15_01

System Operation (15_01)

The equipment works as follows:

1. Releasing the safety lever «B»:

Before activating the load bed tilting system, disengage the tailboard release handle and the safety lever «B».

2. Lifting the load bed:

Pressing the «A» control pushbutton closes the electrical circuit and the battery power activates the electrical motor and the pump. The hydraulic fluid contained in the reservoir is pumped into the load bed lifting mechanism. Releasing the pushbutton stops the load bed in any position.

3. Load bed lowering:

Pressing the «A» control pushbutton causes the hydraulic fluid to be discharged into the by-pass distributor, which causes the load bed to lower due to its own weight. Releasing the pushbutton stops the load bed in any position.

The tilting is controlled by the special button "A" located on the right side control panel for the steering wheel version and above the indicator assembly for the handlebar version.

A = Control key.

B = Safety lever.

The safety lever "B" can take two different positions:

0 = Load bed unlocked with the possibility of being tipped.

1 = Load bed locked in rest position.

4. Once the tilting operations have been completed move the «B» safety lever to the 1st position.

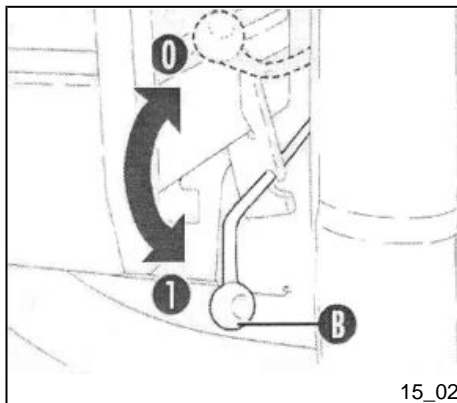

In order to improve safety and prevent unintentional operations, the lifting control only becomes live after releasing the safety lever on the right hand side at the back of the cabin.

Remember to bring the safety lever back onto the 'blocked' position once all tilting operations are completed.

- **TIPPING ACTIONS OF THE PLATFORM MUST BE CARRIED OUT WHEN THE VEHICLE IS STOPPED AND THE HANDBRAKE ENGAGED.**

Safety devices

The tilting system has four components that guarantee maximum safety:

1. Safety lever «**B**» that locks the load bed when not engaged in tilting operations. In fact to start any operation, the lever «**B**» must be moved upwards.
2. Light indicator (red coloured) positioned into the cab, which indicates the tilting of the load bed.
3. System overpressure safety valve
4. Anti-extraction piston that allows securing the load bed in lifted and intermediate position even while the engine is off.

Warnings for Loading and Unloading Operations (15_03, 15_04)

The operator must be in the driving position to use the equipment to be able to operate quickly and effectively the normal and emergency controls. During the loading and unloading operations the operator must take the following precautions.

- For avoiding the risk of instability during use; before carrying out loading and unloading operations, park the vehicle on an even, horizontal surface and check the side board and tailgate locking and blocking systems.
- Loading should be gradual and the weight of the loaded cargo must not exceed the vehicle's allowable load mass (overall and per axle). The load should be evenly distributed on the load bed. If the load is not evenly distributed on the platform, check the following:
- abnormal stress on the mechanical parts and vehicle's instability during driving.
- abnormal stress on the equipment components and risk of vehicle overturning during the tilting operation.
- The cargo height must be proportional to the density or specific gravity of the loaded material. The allowable load capacity is around 700 kg and proportional to the cargo height.
- up to the side board rim in the case of light, loose material (grains or by-products).
- up to the middle of the side board in the case of inert materials (sand, gravel compost or similar materials).
- when loading blocks or objects check their position to ensure an evenly distributed load on every axle.

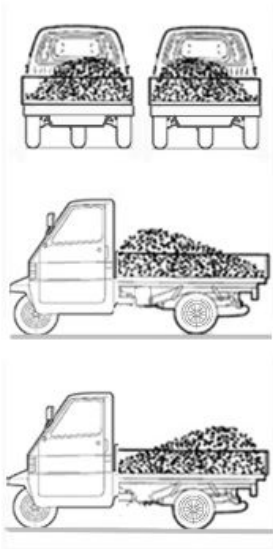

15_03

During unloading operation check:

- that the tailboard is open. Otherwise, stop the unloading operation immediately and set the load bed at rest; do not force the side boards open when the load bed is in tilted position.
- Carry out gradual unloading until the load bed is completely empty.
- In order to avoid risks of injury to people or damage to objects due to falling objects park the vehicle away from other people's working zone and from objects or structures that may damage the cargo, also taking into account the type of loaded material;
- In case of unloading the cargo inside a building, check the free ceiling height and the distance from any other possible structural parts of the building (pipelines, electrical conductors, etc.) in order to ensure that the load bed can be tilted completely, also taking into account the height increase due to the extension of the shock-absorbers In any case, do not lift the loading surface near live electrical lines or gas pipes to avoid the risk of contact or failure to keep a minimum safe distance.

An adequate load bed cover must be installed when transporting reduced density loads (granular or powdered material, light material, fragments, scrap, etc.) or material that can be lifted and blown away by the wind.

In any case, the height of the bulk material loaded must not exceed the height of the side board.

It is strictly forbidden to stand near or underneath a lifted, loaded loading surface without securing the safety bar and **provided the vehicle is empty**

It is risky to lift the load bed when the wind blows strong

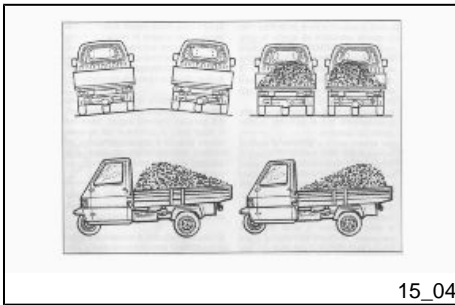

The vehicle load must not exceed the maximum tolerances set for in the Road Regulations or the allowable tolerances specified by the manufacturer. For information on load tolerances (overall and per axle) refer to the Technical Specifications section. The value for the overall mass is given in the vehicle registration papers.

Remember that loading the vehicle in excess of the values given in the Traffic Regulations and on the manufacturer's plate, even for short trips, runs the serious risk of damage to the vehicle due to the excessive stress exerted on the vehicle's parts and on the tipping components, and may also result in sanctions under Traffic Regulations regarding overloading.

Scheduled Maintenance

CAUTION

WARNING



BEFORE CARRYING OUT ANY OPERATION WITH THE LOAD BED TILTED AND UNLOADED, IT WILL BE NECESSARY TO FIT THE SPECIAL PROP HINGED ON-TO THE CHASSIS AND INSERTED INTO THE ATTACHMENT UNDERNEATH THE LOAD BED. SUCH A DEVICE MUST BE REPLACED ONLY AFTER THE OPERATION HAS BEEN COMPLETED AND BEFORE THE LOAD BED IS LOWERED.

Counter-chassis attachments and connections to the chassis

Ensure all bolts securing the counter-chassis to the chassis are tightened and, if necessary, tighten any loosen bolt.

Hinges

Ensure the hinges are free to move and have no excessive clearance or deformation.

Cylinder and jack

Check that the jack stem is properly extended and that it is free of scratches, dents or deformations. In the event of faults, please contact the manufacturer or an authorised workshop.

Hydraulic system piping and valves

Ensure the pipes, joints, and fittings on all components are leak free. In particular, check the flexible pipes are not damaged. In the event of faults, please contact the manufacturer or an authorised workshop.

Lubrication and greasing

All system moving components must be lubricated with oil or grease every 25 working hours and again every 30 - 40 days, according to the operating environment (moist, fine sand, dust, or polluting or corrosive substances, etc.). Lubricated pins and hinges with suitable grease.

Hydraulic oil

Check the oil level and, if necessary, top it up. If the load bed fully tilted, take into account the amount of oil inside the cylinder.

- Use only recommended hydraulic fluid.
- Do not mix the oil with another type.
- Replace the fluid completely every 4 years and clean the reservoir.
- Replace the oil completely every 150/200-work hours.

Recommended products

AGIP ARNICA 46

HV hydraulic oil (High viscosity index).
ISO-L-HV; DIN 51524-3 HVLP.

Pneumatic and electrical control circuits, controls and warning lights.

Check the standard operation of the controls, warning lights and relevant circuits and pipes. In the event of faults, please contact the manufacturer or an authorised workshop.

Structural components

Check that all structural components are free of faults such as bending, breakage, detached components, welding cracks etc. If any faults are noted, contact the manufacturer or a specialised repair centre.

Extraordinary Maintenance

Such operations consist of all interventions aimed at:

- fix leaks within the hydraulic circuit;
- checking, repairing, or replacing the hinges, pins, oil seals constituting the tilting mechanism and lifting jack;
- checking or replacing the end-stroke device, the hydraulic control unit and warning light;
- checking or repairing the body structure or any other component of the upper structure.

The lifting system may be affected by several different causes of failure. In such circumstances, after following all instructions given within the manual, it is necessary to carry out a troubleshooting session.

Trouble-Shooting

Body does not start lifting and control unit does not emit any noise

Possible cause:

- no supply (low battery, loose terminals).
- supply to the electrical circuit is interrupted (defective fuse, faulty switch, loose electrical connections).
- end-stroke device jammed.

Solutions to be undertaken:

- check the battery and the supply circuits
- replace the fuse
- check the control switch
- check the end-stroke device

Body does not start lifting but there is a noise coming from the control unit

Possible cause:

- no oil in the tank
- the pipe connecting the pump to the cylinder is obstructed or leaking
- electric motor is faulty
- pump is faulty
- distributor by-pass faulty
- excessive load on body or vehicle parked on a slope

Solutions to be undertaken:

- check the oil level inside the reservoir and top-up if necessary
- check the pipes, electric motor, pump, and distributor

Body lifts only partially

Possible cause:

- early engagement of end-stroke device
- insufficient oil inside reservoir

Solutions to be undertaken:

- check the end-stroke device
- check the oil level

Body does not come down**Possible cause:**

- control switch faulty
- clogged exhaust pipe
- by-pass defective

Solutions to be undertaken:

- check the control switch, pipes and by-pass

Body lifts without activating the controls**Possible cause:**

- control switch or electric circuits defective (short-circuit)

Solutions to be undertaken:

- check the insulation of the control switch and electric circuit.

Body does not stop after releasing the pushbutton**Possible cause:**

- distributor retaining valve defective

Solutions to be undertaken:

- check the distributor

Warning light and buzzer stay on

Possible cause:

- switch faulty

Solutions to be undertaken:

- check the switch

Warning light and buzzer not working**Possible cause:**

- warning light bulb defective or buzzer faulty (if only one of the two not working)
- switch or electric circuit faulty if both not working

Solutions to be undertaken:

- check: switch, electrical circuits, warning light bulb, and buzzer

Tailgate remains shaft when body is tilted**Possible cause:**

- automatic release mechanism faulty

Solutions to be undertaken:

- check possible faults or defects within the release mechanism

Tailgate remains open after body has lowered completely**Possible cause:**

- automatic release mechanism faulty
- incorrect position of adjusting bolt

Solutions to be undertaken:

- check possible faults or defects within the release mechanism
- check the position of the adjusting bolt

Warning Plate Symbols (15_05)

All labels are fitted individually or in series in different parts of the vehicle: counter-chassis, instrument panel, side boards, etc...

A



B



C



D



E



F



G



H



15_05

NOTE - LABELS

A	READ THIS MANUAL CAREFULLY AND FOLLOW THE INSTRUCTIONS IT CONTAINS.
B	KEEP AT A SAFE DISTANCE FROM THE VEHICLE
C	DO NOT REST UNDER THE LIFTED LOADING PLATFORM IF THE SAFETY BAR HAS NOT BEEN SECURED.
D	STOP THE ENGINE AND REMOVE THE KEY AND THE EMERGENCY FUSE BEFORE CARRYING OUT MAINTENANCE OPERATIONS.
E	DO NOT PARK THE VEHICLE DOWNHILL OR ON LOOSE SOIL.
F	DO NOT STAND NEAR THE DANGER ZONE IF THE LOADING PLATFORM IS LIFTED.
G	WEAR GLOVES TO AVOID CONTACT WITH HOT PARTS.
H	WEAR GLOVES TO AVOID INJURY BY HIGH-PRESSURE FLUIDS.

technical sheet for EC conformity declaration

This manual contains information on the vehicle's tilting system.

Thorough knowledge of the manual's content is fundamental to ensure proper use and adequate functioning of the installed equipment.

Even in the case of equipment that is easy to use, operators must be familiar with common safety measures and must pay special attention during manoeuvring in order to ensure proper vehicle operation at the various stages of the operating cycle. Proper use of equipment is fundamental to avoid any possible risk and reduces the frequency of maintenance operations, thus enhancing the durability of the vehicle's components. The operator should carry out the various procedures very carefully to avoid injury to himself, other people or objects. The vehicle has been designed for unloading and transporting loose, solid material or blocks. The loading body can be tilted backwards for cargo unloading.

The builder shall not be liable for any damage caused by failure to observe the instructions herein contained or caused by improper or forbidden use or damage due to misuse, inadequate or incomplete maintenance of the equipment or the vehicle. The builder shall not be liable for any replacement, modification or tampering with vehicle components or incorrect maintenance or repair operations carried out by unskilled personnel using inadequate materials.

Modifying or tampering with side boards and tailgate or increasing their height with fixed or movable parts is strictly forbidden. The builder reserves the right to authorise any modification if it is deemed appropriate.

Preface

- Tricycle
- T1 type
- Following version: T1BR/MS - T1BR/VS

The instructions contained in this manual pertain to the tilting equipment and are aimed at the release of the declaration of EC conformity for the vehicles built and complying with the specifications outlined hereby. The validity of the certification is extended to all tilting systems having the same specifications and complying to the standards set

forth in directive 89/392/EEC and amendments, in the 91/368/EEC, 93/44/EEC applicable standards and CUNA standards NC 173-01, 173-02, 173-03,173-04 and 173-05

Reference:

- drawings of the overall vehicle, the chassis, the tilting system components, the control and safety devices.
- Illustrations of the fitted vehicle.

Equipment Layout

The tilting system consists of:

- -a base chassis (cabin with centre member);
- -a counter-chassis built with a pressed-sheet structure bolted onto the base chassis;
- -body resting on a pressed-sheet loading platform and supported by cross-beams and outline section bars; the front headboard and lateral boards are fixed; the tailgate can be tilted and removed; the tailgate, which is equipped with a mechanical closure system, can be lifted upward or downward.

The tailgate locking-release mechanism is activated by moving a control lever.

In the body centre there are hinged bolt fittings connected to the end of the pushing triangle (jack), fixed onto the body by means of an arc-welded pressed sheet structure.

- -two-position lifting jack with special fittings welded onto the base chassis and fastened onto the abovementioned hinge with an appropriate bolt fitted on the upper part
- .

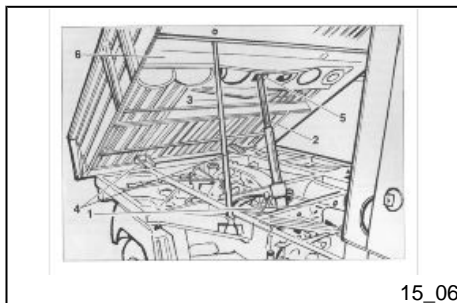

15_06

1. Base chassis.
2. Lifting jack stem.
3. Safety bar.
4. Body hinges.
5. Jack upper pivot attachment
6. Body reinforcing structure.

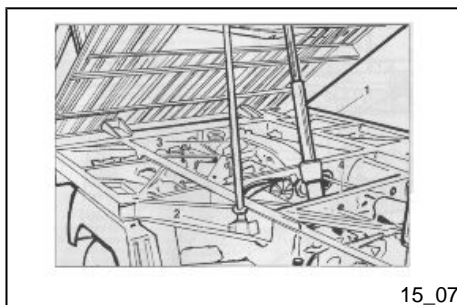

15_07

1. Vehicle's counter-chassis
 2. Safety bar support.
 3. Safety bar.
 4. Base chassis.
- Rear hinges fastened onto appropriate brackets, bolted onto the overhang of rear chassis members.

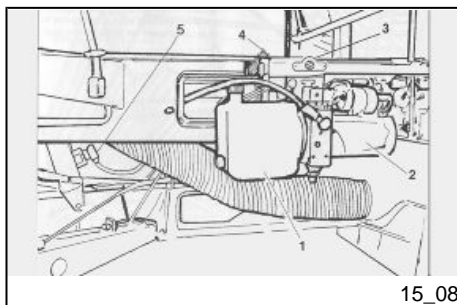

15_08

1. Hydraulic fluid reservoir
2. Pump and pipe fittings connected to jack
3. Buzzer.
4. Switch for indicating lifted body and enabled vehicle start.
5. Drop valve inside the jack.

Hydraulic system consisting of:

- - hydraulic fluid reservoir,

- - pump driven by an electrical motor powered by the vehicle's battery, distributor fitted with a by-pass valve,
- - high-pressure pipelines connecting the pump to the jack,
- - electrical system equipped with controls and safety devices;

Safety devices consisting of:

- - switch for indicating lifted body,
- - buzzer indicating lifted body,
- - movable guard for activating the signalling switch ,
- - body release lever
- - tailgate release lever
- - drop valve mechanism of the jack, which prevents the body overtravel in case of a hydraulic system failure,
- - manually-fitted safety bar hinged onto the body and fastened onto the counter-chassis by a retainer.

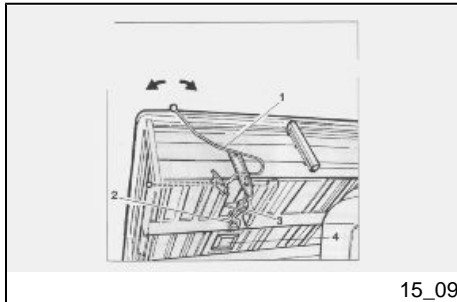

Tilting body front and locking lever.

1. Body release lever
2. Body attachment hook
3. Lever retracting spring.
4. Safety pushbutton guard.

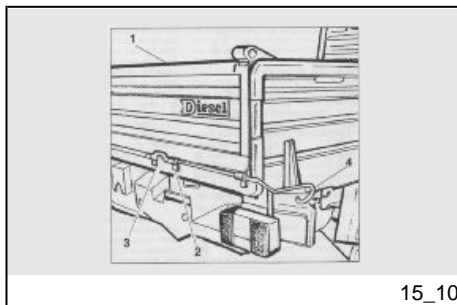

Tailgate and closure mechanism

1. Tailgate
2. Locking lever hinge
3. Locking bolt for closure mechanism.
4. Locking lever

Analysis of Risks Connected with the Layout and Operation of the Equipment

Possible risks are evaluated as per Directive no. 89/392/EEC, as modified and integrated by EEC Directives 91/368, 93/44, 93/68 with regard to the layout and operation of the equipment as applicable to the type and operational specifications of the equipment itself. The operational specifications of the tilting equipment are also examined with reference to the CUNA tables NC 173-01, NC 173-02, NC 173-03, NC 173-04, and NC 173-05.

ESSENTIAL HEALTH AND SAFETY REQUIREMENTS.

Design and Manufacture.

The design and manufacture conform to all requirements set forth in the Directives. They are carried out in conformity with the requirements dictated by the Italian MINISTRY OF TRANSPORT - M.C.T.C. Headquarters, and CUNA standards, where applicable.

The main structural elements are subjected to stability calculations. The safety levels are those imposed by the standards, imposing a safety coefficient not less than 2.5 times the yield stress of the material. The vehicle, in all its variants, has achieved the type homologation. A declaration of conformity is released for each vehicle sold, referring to all its components according to the type ratified. The materials and components used are those listed in the "References for Upper Structure Elements" Section.

The overall equipment design and manufacture, meets the requirements set forth in section 1.1 of the Technical Appendix to the Standards, in addition to the above mentioned CUNA norms.

Controls and control devices.

All controls comply with the applicable Directives regarding the type and operational specifications of the equipment and its use. Operator position: this is the vehicle driver's position. Control position: on the dashboard, to the left of the driving position (for left-hand drive vehicles) or in the opposite position for right-hand drive vehicles.

Controls to be used by operator:

- there is a single control for lifting or lowering the load bed.
- a device fitted with an emergency system. This control is a pushbutton located in the electrical circuit that connects the battery to the hydraulic control unit. This protected circuit is derived from the vehicle's circuit and has two sections:
 - one section supplies the electrical motor connected to the pump.
 - the other one activates the control distributor by-pass.

The control has two properly labelled positions:

- upward arrow indicating lifting.
- downward arrow indicating lowering.

In the resting position the electrical circuits of both sections remain open: the engine is not powered and the by-pass remains closed.

Pushing the switch upwards (as shown by the arrow) closes the load bed supply system. The switch has a latching function. Releasing the switch stops the load bed. Moving the switch downwards (as shown by the arrow) opens the load bed distribution by-pass and starts (or continues) the load bed lowering operation.

The switch has a latching function. Releasing the switch stops the load bed. There are red-light indicators (located on control pushbutton and marked with a symbol indicating lifted load bed) and buzzers that can be heard even from inside the cabin.

The warning indicators are turned on by pressing a pushbutton when disengaging the load bed release lever at the beginning of the lifting operation, and they remain illuminated until the release lever is re-engaged.

The warning lights and buzzers are activated as soon as the load bed lifting operation starts and are deactivated when the load bed reaches its home position.

The hydraulic system efflux lights have been properly adjusted according to the load bed lifting and lowering speed in order to avoid causing undesired stress and hazards, even in case of lifting system failure. The load bed lifting or lowering movements are slow enough to allow the operator to take prompt action in case of incorrect vehicle handling or any other failure.

The emergency control has a removable valve located in the electrical supply circuit, which cuts out power supply, if required. The device can be easily reached and is easy to remove and remount.

All controls and hydraulic equipment comply with the above mentioned CUNA standards.

PROTECTION MEASURES AGAINST MECHANICAL RISKS

Vehicle's stability

Because of its capability of transporting and unloading cargo through load bed tilting, this vehicle presents risks of instability, which may be avoided only through careful operation of the equipment when loading and unloading. Conditions of instability may arise as a result of the irregularity, non-planarity, or poor consistency (collapse) of the ground underneath the vehicle, in addition to the failure of the tailgate release and locking system. As a result of the lightweight load bed construction, instabilities may arise in windy conditions or in the event that the load is not evenly distributed.

The tailgate lock system is designed so that:

- The tailgate remains shut when the load bed is at rest;
- And it opens automatically, through the automatic release mechanism, as soon as the load bed starts lifting.

Precautions for avoiding the risk of instability during use

The precautions to be adopted are given in the instructions and concern the following:

- Position of the vehicle during the loading and unloading operations, in particular, the nature of the wheels' resting surface (non-planarity, irregularity, and poor consistency).
- Loading method with particular reference to the entity, gradualness, and distribution of the cargo.
- Unloading warnings and operations, with particular reference to the automatic release of the tailgate and the intervention of the end-stroke device. There are warning plates with writings or symbols referring to the above mentioned requirements.

Risk of system breakdown during operation

The system is designed and manufactured to withstand the loads experienced during the circulation and the loading and unloading operation, as set forth in the standards. However, it is possible that, following the collapse of a structural element, as a result of overloading or uneven load distribution, or other external causes, the load bed flips backwards or sideways.

Precautions for avoiding the risk of failure during use

The precautions to be adopted are given in the instructions and concern the following:

- Knowledge of the maxim allowed loads for the vehicle (overall and per axle): registration papers, and plate in accordance with EEC Directives 76/114 and 78/507.
- Compliance with the maximum load restrictions, particularly the load bed capacity and load bed height as a function of the density of the material.
- Compliance with the requirements concerning the distribution of the load over the load bed.
- Regular operational inspections of the end-stroke and tailgate automatic release devices.

There are warning plates with writings or symbols referring to the above mentioned requirements.

Risks associated to falling or flying objects

During loading, unloading, or transport, there is a risk of objects falling off the load bed. Such risk may be avoided solely by taking adequate precautions against such contingencies.

Risks associated to falling or flying objects.

The precautions to be adopted are given in the instructions and concern the following:

- Park the vehicle sufficiently far from any workplace or damaging objects.
- Forbidding anyone from approaching the vehicle during unloading.
- Forbidding anyone from approaching the open tailgate during unloading and taking any action to facilitate the fall of the material.
- Forbidding loading the vehicle above the gates' height.
- Special requirements apply to the transport of lightweight materials. There are warning plates with writings or symbols referring to the above mentioned requirements.

Risks due to sharp edged surfaces and angles.

Some components and accessories may pose the risk of injury by accidental collision. Violent collision with metal vehicle parts or accessories, even if these do not have sharp-edged angles or cutting sections, may cause bruises or injuries.

Precautions for avoiding the risks of injury by sharp-edged surfaces or angles.

Safety measures to take into account when operating near exposed vehicle parts or equipment components.

- wear personal protection equipment, particularly during side board removal or when carrying out maintenance operations.

Protection measures against mechanical hazards comply with the requirements set forth in the Directive's technical appendix on "safety measures to avoid mechanical risks" and the above mentioned CUNA standards.

Protective Measures Against Other Hazards

The equipment is driven by hydraulic fluid, which may reach high temperatures during operation, resulting in the danger of burns in the event of leaks from pipes, valves, or fittings. Risk of fire may also result from the fluid coming into contact with high temperature components (e.g. exhaust pipe). Shields of isolating material are located near hot engine parts or exhaust pipe. When unloading indoors the lifted load bed may hit the ceiling or other obstacles.

Precautions for avoiding other hazards

The precautions to be adopted are given in the instructions and concern the following:

- Checking the free ceiling height and the distance from any other possible structural parts of the building in order to ensure that the load bed can be tilted completely, also taking into account the height increase due to the extension of the shock-absorber.
- Forbidding anyone from approaching pressurised hydraulic circuits.
- Forbidding load bed lifting near live electrical lines or gas pipes, to avoid the risk of contact or the observance of the safety distance.
- Forbidding the operation in areas with insufficient lighting.

Protection measures against other hazards comply with the requirements set forth in the Directive's technical appendix and the above mentioned CUNA norms.

Maintenance

Operational maintenance does not involve any risk as it only consists of visual checks and the greasing of parts subjected to wear (e.g. tipping hinges, side and tailgate hinges, hooks and locks), if necessary. Inspecting the counter-chassis attachments does not involve any risk for as long as the load bed is at rest.

All operations requiring the load bed to be lifted, for whatever reason, must only be carried out after the safety prop has been carefully positioned underneath the load bed. The safety prop prevents the load bed from dropping. It does not offer the same safety guarantee when the load bed is loaded. For other maintenance operations or repairs, which require intervention on elements of the upper structure when the load bed is lifted (e.g. fixing of lifting jack and accessory components, pins and hinges replacement), it is mandatory to refer to an authorised workshop equipped with all necessary tools and safety equipment.

Information regarding maintenance is given in the instructions.

Marks and signals

The following instructions contain information regarding equipment operation. The following specifications are indicated on the plate:

- manufacturer's name and address
- CE marking and year of manufacture
- vehicle type and chassis identification number
- device serial number

Conclusions

The overall equipment and all its components comply with the specifications and standards set forth in Directive 89/392/EEC and amendments and 91/368/EEC, 93/44/EEC, 93/68/EEC, in addition to CUNA standards NC 173-01, 173-02, 173-03, 173-04 and 173-05.

N.B.

FOR INFORMATION ON LOAD TOLERANCES (OVERALL AND PER AXLE) REFER TO THE REGISTRATION PAPERS OR THE TECHNICAL SPECIFICATIONS SECTION.

PLATES CONTAINING COMMONLY USED WARNING MESSAGES AND SIGNS ARE LOCATED NEAR VARIOUS EQUIPMENT PARTS

NOTE: For the total mass and the mass on the relative axes, reference should be made to what indicated on the label installed on board the vehicle. In addition, at several points of the device, there are adhesive warning labels with symbols of common use.

Ape TM - Ape TM Diesel



VEICOLI TRASPORTO LEGGERO



Chap. 16
Technical data

VEHICLE LENGTH A

NORMAL BODY	3175 mm
LONG BODY	3390 mm
TILTING BODY	3225/3335 mm(*)
VAN	3210 mm
MOTOR CHASSIS	3150/3210 mm

VEHICLE WIDTH B

NORMAL BODY	1480 mm
LONG BODY	1500 mm
TILTING BODY	1500 mm
VAN	1480 mm
MOTOR CHASSIS	1455 mm

VEHICLE HEIGHT C

NORMAL BODY	1630 mm
LONG BODY	1630 mm
TILTING BODY	1630 mm

VAN	1780 mm
MOTOR CHASSIS	1630 mm

VEHICLE WHEELBASE D

NORMAL BODY	2170 mm(O) - 2130 mm(Δ)
LONG BODY	2170 mm(O) - 2130 mm(Δ)
TILTING BODY	2170 mm(O) - 2130 mm(Δ)
VAN	2130 mm (O)
MOTOR CHASSIS	2170 mm(O) - 2130 mm(Δ)

LOAD COMPARTMENT LENGTH E

NORMAL BODY	1770 mm
LONG BODY	1970 mm
TILTING BODY	1810/1920 (*) mm
VAN	1770 mm

LOAD COMPARTMENT LENGTH F

NORMAL BODY	1420 mm
LONG BODY	1970 mm

TILTING BODY	1810/1920 (*) mm
--------------	------------------

VAN	1770 mm
-----	---------

Vehicle (16_01)

(*) For Diesel versions only.

(O) Handlebar.

(Δ) Steering wheel.

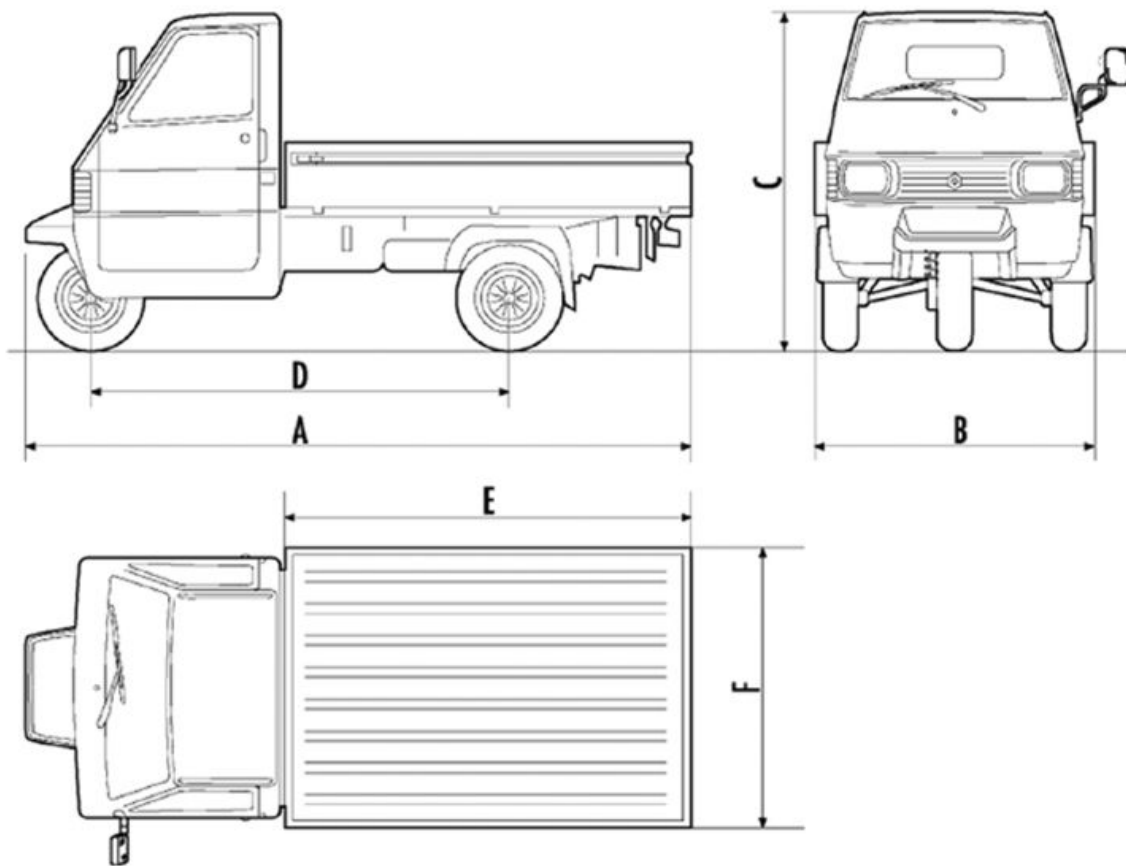

16_01

TECHNICAL SPECIFICATIONS - PERFORMANCE

Engine	Single cylinder, two strokes, with revolving timing system with three transfer ducts.
Bore	68 mm
Stroke	60 mm
Displacement	217.9 cm ³
Compression ratio	8.6 : 1
Ignition advance (before TDC)	14°±1°30"
Carburettor	Dellorto SHBC 22/22
Spark plug	BOSCH W3AC - CHAMPION RL78C - NGK BR8HS
Engine-wheel transmission ratio	- 1st speed = 1/48.47 - 2nd speed = 1/26.54 - 3rd speed = 1/15.57 - 4th speed = 1/9.16 - RM = 1/80.78
Max. speed	60 - 65 km/h

REFUELLING

Gasoline	RESERVE: 3.5 litres
----------	----------------------------

	CAPACITY (including reserve): 15 litres
Mixer oil	RESERVE: 0.75 litres CAPACITY (including reserve): 3 litres
Gearbox oil	CAPACITY (including reserve): 1000 cc

VERSION

Normal body	LOADLESS WEIGHT (with driver): 465 kg CAPACITY (excluding driver): 805 kg MAX WEIGHT: 1270 kg
Long body	LOADLESS WEIGHT (with driver): 465 kg CAPACITY (excluding driver): 805 kg MAX WEIGHT: 1270 kg
Tilting body	LOADLESS WEIGHT (with driver): 505 kg CAPACITY (excluding driver): 765 kg MAX WEIGHT: 1270 kg

Van	LOADLESS WEIGHT (with driver): 505 kg CAPACITY (excluding driver): 765 kg MAX WEIGHT: 1270 kg
Fixed motor chassis	MAX WEIGHT: 1270 kg
Tilting motor chassis	MAX WEIGHT: 1270 kg

TECHNICAL SPECIFICATIONS - PERFORMANCE

Engine	Diesel cycle, 4 strokes, indirect injection, single cylinder
Bore	83 mm
Stroke	78 mm
Engine capacity	422 cm ³
Compression ratio	23 : 1
Static start advance	11° - 24° before TDC
Dynamic advance	13° - 25° ±1 before TDC

Engine-wheel transmission ratio - 5 gear version (Steering wheel)

- 1st speed = 1/39.8
- 2nd speed = 1/24.7
- 3rd speed = 1/15.8
- 4th speed = 1/10.4
- 5th speed = 1/6.8

- RM = 1/39.8

Engine-wheel transmission ratio - 4 gear version (handlebar)	- 1st speed = 1/35.4 - 2nd speed = 1/19 - 3rd speed = 1/10.9 - 4th speed = 1/7.1 - R.M. = 1/35.4
Maximum speed	~ 65 km/h

REFUELLING

Diesel	CAPACITY 15 litres (reserve: 3.5 litres)
Engine oil	CAPACITY: 2.8 lt. (3.5 tot. system)

VERSION

Long body	LOADLESS WEIGHT (with driver): 515 kg CAPACITY (excluding driver): 755 kg MAX WEIGHT: 1270 kg
Tilting body	LOADLESS WEIGHT (with driver): 555 kg

CAPACITY (excluding driver):
715 kg

MAX WEIGHT: 1270 kg

Motor chassis

MAX WEIGHT: 1270 kg

TECHNICAL SPECIFICATIONS

Fuel supply	By an injection pump, fed by a membrane pump.
Fuel	Automotive diesel
Lubrication	Pressure by lobe pump.
Oil filter	With cartridge and total capacity.
Timing system	Camshaft on the cylinder head, controlled by a toothed belt.
Water cooling,	Permanent forced coolant circulation system.
Air filter	With dry filtering cartridge.
Transmission	From crankshaft to the rear wheels via clutch, assembly of gearbox - differential - axle shafts and flexible couplings.
Clutch	Single disc with lever control (left side of the handlebar) or by pedal for the steering wheel version; adjustable flexible transmission.
Gearbox	With four gears on the handlebar version with always driven gears.

	With 5 gears on the steering wheel version.
Differential	<p>Connected to the gearbox shaft by cylindrical gears. The planetary and satellite gears are bevel.</p> <p>The differential box is connected to the two axle shafts that transmit the motion to the wheels by flexible couplings. The differential is equipped with a gear reversing device.</p>
Start up	With electric motor and key control.
Exhaust silencer	Expansion and absorption-type exhaust silencer.
Steering and suspensions	<p>Steering wheel tube pivoted on the arm with front wheel-holder oscillating hub. Front suspension with helical spring and hydraulic coaxial shock absorber. To compensate the suspension load, the front wheel is tilted by approx. 1.5° relative to the vertical axle.</p> <p>Independent rear suspensions with oscillating triangular arms with rubber pad and variable flexibility at each wheel; the hydraulic shock absorbers are coaxial to the spring members.</p> <p>The rear suspensions are manufactured so as to have a longer stroke than the former models, to improve driving comfort.</p> <p>With stationary and loadless vehicle, the wheel setup is inclined by about 6.5° in relation to said</p>

stroke; in full load condition, the wheels have a vertical setup.

Brakes	<p>With expansion on the three wheels:</p> <p>Front and rear with hydraulic control by pedal and direct controlled brake pump.</p> <p>- Safety or parking with mechanical control on the rear wheels. The control lever is located on the central instrument panel column in the driving cabin. The brakes are provided with a shoe self-adjustment device that automatically and continuously restores the proper clearance between blocks and drums, regardless of the friction material wear.</p>
Wheels	Pressed sheet metal rim 3.50-12
Front tyre - Handlebar	4.00-12CN TL
Rear tyre - Handlebar	125R12C XZX TL
Front tyre- Steering wheel	125R12C XZX TL
Rear tyre - Steering wheel	125R12C XZX TL
Front tyre pressure	2.5 atm
Rear tyre pressure	4.5 atm
Injection system	In the diesel engine, the fuel is injected at the end of the compression stroke in the pre-chamber through the injection pump.

The amount injected for each cycle is adjusted, depending on the power required, through the rotation of the pumping element of the injection pump by the adjustment bar.

Fuel supply control

The adjustment bar is actuated by the regulator. It is flanged on the side of the engine head and is pulled by a shaft actuated by the camshaft.

The main functions of the regulator are:

- Adjusting the engine idle speed;
- Maximum engine speed limitation;
- Increase of the capacity during start up

Toolkit

A lifting jack.

A pipe wrench with 17-21 mm apertures.

A dual screwdriver (for cross slotted and straight screws).

A 12 mm wrench for preheat glow plug removal.

Ape TM - Ape TM Diesel



VEICOLI TRASPORTO LEGGERO



Chap. 17
Scheduled
maintenance -
Checks

Scheduled maintenance service

SERVICE SCHEDULE

Adequate maintenance is fundamental to ensure long-lasting, optimal operation conditions and performance.

For this purpose, PIAGGIO offers a series of checks and maintenance operations to be performed at the owner's expense, which are summarised in the table on the next pages.

Any minor faults should be reported without delay to an **Authorised Piaggio Dealer or Service Centre** without waiting until the next scheduled service to solve it.

Service the vehicle at the prescribed mileage.

The warranty will not apply unless the Scheduled Services, specified for the guarantee period you choose, are carried out.

Failure to carry out the scheduled services will automatically invalidate the warranty. For further information regarding Warranty procedures and «Scheduled Maintenance», please refer to the «Warranty Booklet».

MAINTENANCE OPERATIONS (gasoline version)

AT 1,000 KM

Braking system - vehicle test/check

Locking external nuts and bolts - check

Parking brake - check/adjust

Brake pump tank oil level - check

Gearbox, gas and clutch control - check/adjust
Belt tension - tension check/adjust
Electric system and batteries - efficiency check
Gearbox oil - replacement
Headlights - check/adjust
Idle carburation - check/adjust
Tyre pressure - check

**AT 4,000 KM AT 20,000 KM AT 28,000 KM AND AT
44,000 KM**

Braking system - vehicle test/check
Parking brake - check/adjust
Brake pump tank oil level - check
Belt tension - tension check/adjust
Spark plug - check/clean/electrodes adjustment
Tyre pressure - check
Battery - check/top up
Levers and engine side controls - lubricate
Differential gearbox unit oil level - check
Carburation - check
Carburettor - Cleaning
Hinges and door closures - lubricate

Air filter and SAS box (sponge) - clean

SAS reed support - check

**AT 8,000 KM AT 16,000 KM AT 32,000 KM AND AT
40,000 KM**

Braking system - vehicle test/check

Locking external nuts and bolts - check

Parking brake - check/adjust

Brake pump tank oil level - check

Gearbox, gas and clutch control - check/adjust

Belt tension - tension check/adjust

Electric system and batteries - efficiency check

Gearbox oil - replacement

Spark plug - check/clean/electrodes adjustment

Headlights - check/adjust

Idle carburation - check/adjust

Tyre pressure - check

Cylinder head, piston head, discharge lights, exhaust pipe - clean

Battery - check/top up

Levers and engine side controls - lubricate

Differential gearbox unit oil level - check

Carburation - check

Carburettor - Cleaning

Hinges and door closures - lubricate

Air filter and SAS box (sponge) - clean

SAS reed support - check

AT 12,000 KM AND AT 36,000 KM

Braking system - vehicle test/check

Parking brake - check/adjust

Brake pump tank oil level - check

Belt tension - tension check/adjust

Spark plug - check/clean/electrodes adjustment

Tyre pressure - check

Battery - check/top up

Levers and engine side controls - lubricate

Differential gearbox unit oil level - check

Carburation - check

Carburettor - Cleaning

Hinges and door closures - lubricate

Air filter and SAS box (sponge) - clean

SAS reed support - check

SAS reed support - replacement

AT 24,000 KM AND AT 48,000 KM

Braking system - vehicle test/check

Locking external nuts and bolts - check

Parking brake - check/adjust

Brake pump tank oil level - check

Gearbox, gas and clutch control - check/adjust

Belt tension - tension check/adjust

Electric system and batteries - efficiency check

Gearbox oil - replacement

Spark plug - check/clean/electrodes adjustment

Headlights - check/adjust

Idle carburation - check/adjust

Tyre pressure - check

Cylinder head, piston head, discharge lights, exhaust pipe - clean

Battery - check/top up

Levers and engine side controls - lubricate

Differential gearbox unit oil level - check

Carburation - check

Carburettor - Cleaning

Hinges and door closures - lubricate

Air filter and SAS box (sponge) - clean

SAS reed support - check

Scheduled maintenance service

DIESEL VERSION

AFTER 1,000 KM

Braking system - Test drive - Inspection

Brake fluid level - Check

External nuts and bolts lock - Inspection

Tappets - Inspection/Adjustment

Gearbox, gas and clutch control - Inspection/Adjustment

Electric system and batteries - Efficiency check

Injection dynamic advance and timing belt tension - Inspection

Tyre pressure - Inspection

Engine oil - Replacement

Oil filter - Replacement

AT 5,000 KM; AT 15,000 KM; AT 25,000 KM; AT 35,000 KM; AT

45,000 KM AND AT 60,000 KM

Braking system - Test drive - Inspection

Tappets - Inspection/Adjustment

Brake fluid level - Check

Preheat glow plug - Inspection

Tyre pressure - Inspection

Cylinder head, piston head, exhaust pipe, water radiator - Cleaning

Levers and controls engine side - Greasing

Engine oil - Replacement

AT 10,000 KM; AT 30,000 KM AND AT 50,000 KM

Braking system - Test drive - Inspection

External nuts and bolts lock - Inspection

Tappets - Inspection/Adjustment

Brake fluid level - Check

Gearbox, gas and clutch control - Inspection/Adjustment

Electric system and batteries - Efficiency check

Engine oil - Replacement

Oil filter - Replacement

Preheat glow plug - Inspection

Injection dynamic advance and timing belt tension - Inspection

Tyre pressure - Inspection

Cylinder head, piston head, exhaust pipe, water radiator - Cleaning

Levers and controls engine side - Greasing

Engine oil level - Inspection

Hinges, door closures and flexible transmissions - Greasing

Fuel filter - Replacement

Air filter - Replacement

Cooling circuit pipes - Inspection

AT 20,000 KM; AT 40,000 KM AND AT 70,000 KM

Braking system - Test drive - Inspection

External nuts and bolts lock - Inspection

Tappets - Inspection/Adjustment

Brake fluid level - Check

Gearbox, gas and clutch control - Inspection/Adjustment

Electric system and batteries - Efficiency check

Preheat glow plug - Inspection

Injection dynamic advance and timing belt tension - Inspection

Tyre pressure - Inspection

Cylinder head, piston head, exhaust pipe, water radiator - Cleaning

Levers and controls engine side - Greasing

Hinges, door closures and flexible transmissions - Greasing

Cooling circuit pipes - Inspection

 Engine oil - Replacement

 Oil filter - Replacement

 Fuel filter - Replacement

 Air filter - Replacement

 Coolant - Replacement

RECOMMENDED PRODUCTS

Product	Description	Specifications
AGIP CITY TEC 2T	Oil for 2-stroke petrol engines	JASO FC, ISO-L-EGD Specifications
AGIP ROTRA MP 80W-90	Oil with specifications SAE 80W-90, API GL-5	Gearbox oil
AGIP BRAKE 4	Brake fluid	Specifications - FMVSS DOT 4
AGIP GREASE PV 2	Multipurpose grease	NLGI 2 specifications; ISO-LXBIB2
AGIP ARNICA 46	Oil for hydraulic tilting system pump	Oil for hydraulic circuits corresponding to specific ISO VG 46, DIN 51524 HVLP
AGIP SUPERDIESEL MULTIGRADE 15W-40	Engine oil (recommended for warm climates)	SAE 15W-40, API CF-4/SG

TABLE OF CONTENTS

B

Belt: 33, 34

C

Checks: 14, 149

Control: 57

D

Doors: 27

E

Engine: 18–21, 30, 76, 84

F

Filter: 76, 78, 85

Fluid: 79, 80, 83, 84

Fuel: 68, 85, 86

Fuses: 88

I

Identification: 7, 8

Instrument panel: 35

K

Keys: 28

L

Level: 76, 79–81, 83

Lights: 55

Locks: 27

M

Maintenance: 72, 75, 114,
116, 149, 150, 155

Mirrors: 61

O

Oil: 76, 78, 81

P

Pressure: 92

S

Safe riding: 11

Safety: 31–34

Safety belts: 31, 32

Seats: 31

Switch: 53

System: 57, 67, 91, 110

T

Tyres: 91

V

Vehicle: 8, 13, 138

W

Warning: 55, 120

Wheel: 39, 41, 72

Windows: 29



VEICOLI TRASPORTO LEGGERO

© Copyright 2012 - PIAGGIO & C. S.p.A. Pontedera.

All rights reserved. No part of this publication may be reproduced.

This publication has been edited by:

After sales - PIAGGIO & C. S.p.A.

V.le Rinaldo Piaggio, 23 - 56025 PONTEDERA (Pi)

ITALY

www.piaggio.com